

Technical Description

CoboShift Tool Changers ATC/MTC18

M0121-1

Tool changers | Swivels | Swivel tool changers | Grippers | Hose packages | Valve units | Tool systems



COBOSHIFT[™]
BY ROBOT SYSTEM PRODUCTS

rsp robot system
products

The information in this document is subject to change without prior notice and should not be regarded as an undertaking from Robot System Products AB. Robot System Products AB assumes no responsibility for errors that may occur in this document.

Robot System Products AB bears no responsibility for damage that is incurred by the use of this document, or the software or hardware described in this document.

The document, or parts of it, may not be reproduced or copied without prior permission from Robot System Products AB. It may neither be imparted to a third party, nor otherwise be used without authorization. Infringement hereof will be subject to action in accordance with the applicable laws.

Further copies of this document can be obtained from Robot System Products AB at current prices.

© Robot System Products AB

Robot Systems Products AB
Isolatorvägen 4
SE-721 37 Västerås
Sweden

CONTENTS

1 INTRODUCTION	5
1.1 RSP tool changer	6
1.2 Documents.....	6
1.3 Wear parts.....	6
1.4 Complementary equipment	6
2 TECHNICAL SPECIFICATIONS	7
2.1 Description of tool changers and tool attachments	7
2.1.1 Coordinate System Definition.....	8
2.1.2 CoboShift Tool Changer, ATC18-4. Article: P1181.....	9
2.1.3 CoboShift Tool Attachment, ATA18-4. Article: P1182	10
2.1.4 CoboShift Tool Changer with 8 electric signals, ATC18-4 8E. Article: P1187	11
2.1.5 CoboShift Tool Attachment with 8 electric signals, ATA18-4 8E. Article: P1188.....	12
2.1.6 CoboShift Tool Changer with 15 electric signals, ATC18-4 15E. Article: P1191	13
2.1.7 CoboShift Tool Attachment with 15 electric signals, ATA18-4 15E Article: P1192.....	14
2.1.8 CoboShift Manual Tool Changer, MTC18-4. Article: P6018	15
2.1.9 CoboShift Manual Tool Attachment, MTA18-4. Article: P6019	16
2.1.10 CoboShift Manual Tool Changer with 8 electric signals. Article: P6020	17
2.1.11 CoboShift Manual Tool Attachment with 8 electric signals. Article: P6021.....	18
2.1.12 CoboShift Manual Tool Changer with 15 electric signals. Article: P6022	19
2.1.13 CoboShift Manual Tool Attachment with 15 electric signals. Article: P6023.....	20
2.1.14 Pneumatic diagram for CoboShift tool changer ATC18/ATA18	21
2.1.15 Pneumatic diagram for CoboShift manual tool changer MTC18/MTA18.....	21
2.2 Options.....	22
2.2.1 CoboShift Signal Module, 8 signals, robot side. Article: P1179	22
2.2.2 Circuit diagram E0185-087 for P1179.....	23
2.2.3 CoboShift Signal Module, 8 signals, tool side. Article: P1180	24
2.2.4 Circuit diagram E0185-088 for P1180.....	25
2.2.5 CoboShift Signal Module, 15 signals, robot side. Article: P1189	26
2.2.6 Circuit diagram E0185-100 for P1189.....	27
2.2.7 CoboShift Signal Module, 15 signals, tool side. Article: P1190	28
2.2.8 Circuit diagram E0185-101 for P1190.....	29
2.2.9 CoboShift power and signal Module, 7 signals, robot side. Article: P1193.....	30
2.2.10 Circuit diagram E0185-103 for P1193.....	31
2.2.11 CoboShift power and signal Module, 7 signals, tool side. Article: P1194	32
2.2.12 Circuit diagram E0185-102 for P1194.....	33
2.2.13 Tool stand kit for TA18-4. Article: P1185	34
3 SPARE PARTS	35
3.1 Part list for CoboShift tool changer P1181	35
3.2 Part list for CoboShift tool changers P1187 and P1191	36
3.3 Part list for CoboShift manual tool changer P6018	37
3.4 Part list for CoboShift manual tool changers P6020 and P6022.....	38
3.5 Part list for CoboShift signal module P1179 and P1189.....	39
3.6 Part list for CoboShift signal module P1193.....	40

1 INTRODUCTION

Robot System Products is a front-rank provider of peripheral products for high performance robot applications. We provide complete system solutions for your robot installations, aiming to improve your productivity with the most reliable and cost-effective tooling on the market. Continuously we explore emerging technologies, working with leading edge design.

Robot System Products has a wide range of standard robot peripheral products:

- Tool changers
- Swivels
- Swivel tool changers
- CiRo
- Grippers
- Hose Packages
- Valve units
- Tool systems
- Tool parking systems

Robot System Products' tool changers are constructed to maximize the flexibility and reliability of your robot fleet. Through our patented locking device TrueConnect™ robustness and high safety are combined with low weight and compactness. With our swivels compressed air, water, electrical and data signals as well as weld and servo power are transferred to your tools with robot motion capabilities fully maintained. Our swivel tool changers unite the TrueConnect™ mechanism with our swivel technology, combining the best out of the two technologies. With RSP's cost-effective CiRo, cables and hoses can be freely selected with high robot flexibility maintained, and space requirements reduced. Our integrated tool systems are delivered as complete plug-and-play solutions designed for quick and simple installation.

Robot System Products' product lines are available for all major robot brands and come with complete documentation. 3D-models for simulation are available for download at: robotssystemproducts.com.

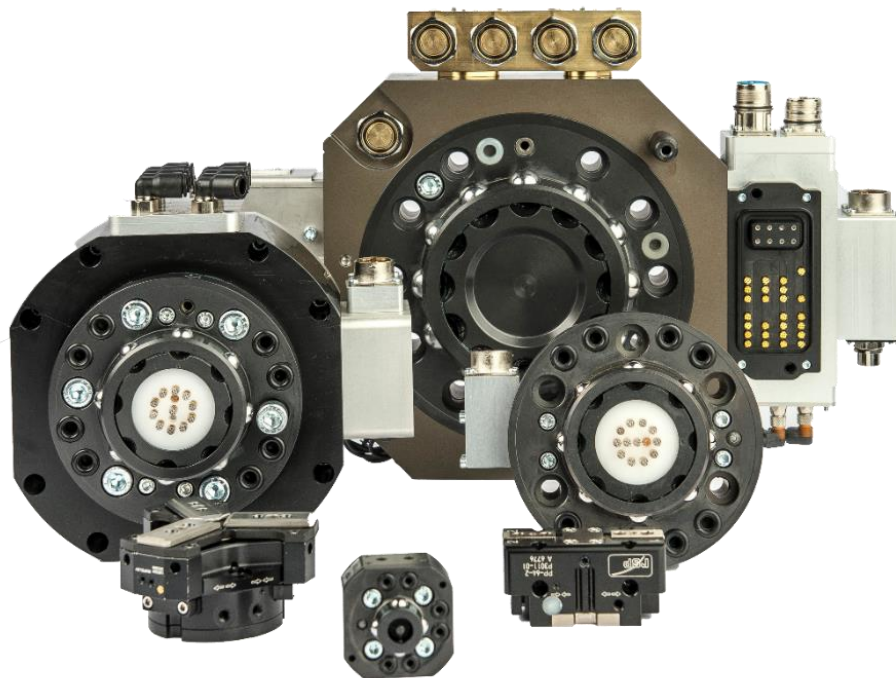

1.1 RSP tool changer

The Robot System Products' tool changers enable robots to handle and switch between multiple tools. They are built to ensure reliable and smooth operation, being compact with low weight and robust design and incorporating many safety features. Depending on model and options, electrical signals, weld and servo power, data, water and compressed air are transferred from the robot side to the tool.

The patented locking device TrueConnect™ has a minimum of play and gives a practically, through the lifespan, absolute positioning repeatability. The principle behind the locking mechanism is the uniform distribution of load obtained by pressing locking balls into spherical grooves. In consequence, substantially larger positional tolerances are accepted during docking.

1.2 Documents

This *Technical Description* contains product information and data, drawings, circuit and pneumatic diagrams and lists of spare parts. In the document *Installation and Maintenance* (M0119-1) procedures for mounting, installation and replacement of equipment are described together with descriptions of inspection, cleaning and lubrication activities including recommended maintenance intervals.

1.3 Wear parts

Wear parts should be replaced before considerable damage occurs. The interval depends on the number of tool changes and its working environment. Generally, the more contaminated environment, the closer maintenance intervals.

The following parts are considered as wear parts:

- Signal pins
- Air sealings
- O-rings

1.4 Complementary equipment

Complementary equipment is described in separate documents.

Article	Note
External valve units	Mounted at the rear of the upper arm. Shuts off the air automatically during tool changing.
Tool parking systems	RSP tool parking systems give rigid installations for easy tool changing.
Connection kits	Connection kits for tool changers and tool attachments simplifying electrical installations.
3D-models	Available in Solid Works®, STEP and Parasolid-format.

2 TECHNICAL SPECIFICATIONS

2.1 Description of tool changers and tool attachments

This document presents the Robot System Products CoboShift tool changers ATC18 and MTC18 including tool attachments dedicated for collaborative robots. Likewise presented are adaptation kits and a tool stand kit.

The tool changers ATC18-4 and MTC18-4 transfer compressed air to the tool, they cannot transport fluids. ATC18 and MTC18 can be equipped for transfer of electric and power signals, via spring loaded signal pins and power pins and sockets, to the tool attachment. The electrical versions are designated 'E'.

The electrical unit is primarily intended for transfer of sensor signals from tools.

For other bolt circles adaptation plates between the tool changer and the turning disc on the robot may be needed. Such adaptation plates are available from RSP.

There may be some limitations on the movement of axis 5 for some robot models. Contact Robot System Products for more information.



ATC18-4 8E

2.1.1 Coordinate System Definition

A tool changer adds load to the robot. If the arm and tool loads are not stated correctly during programming the behaviour of the robot and the wear of the equipment will be affected. Information about weight and centre of gravity can, in accordance with the co-ordinate system stated below, be found in the technical specification tables of the tool changer.

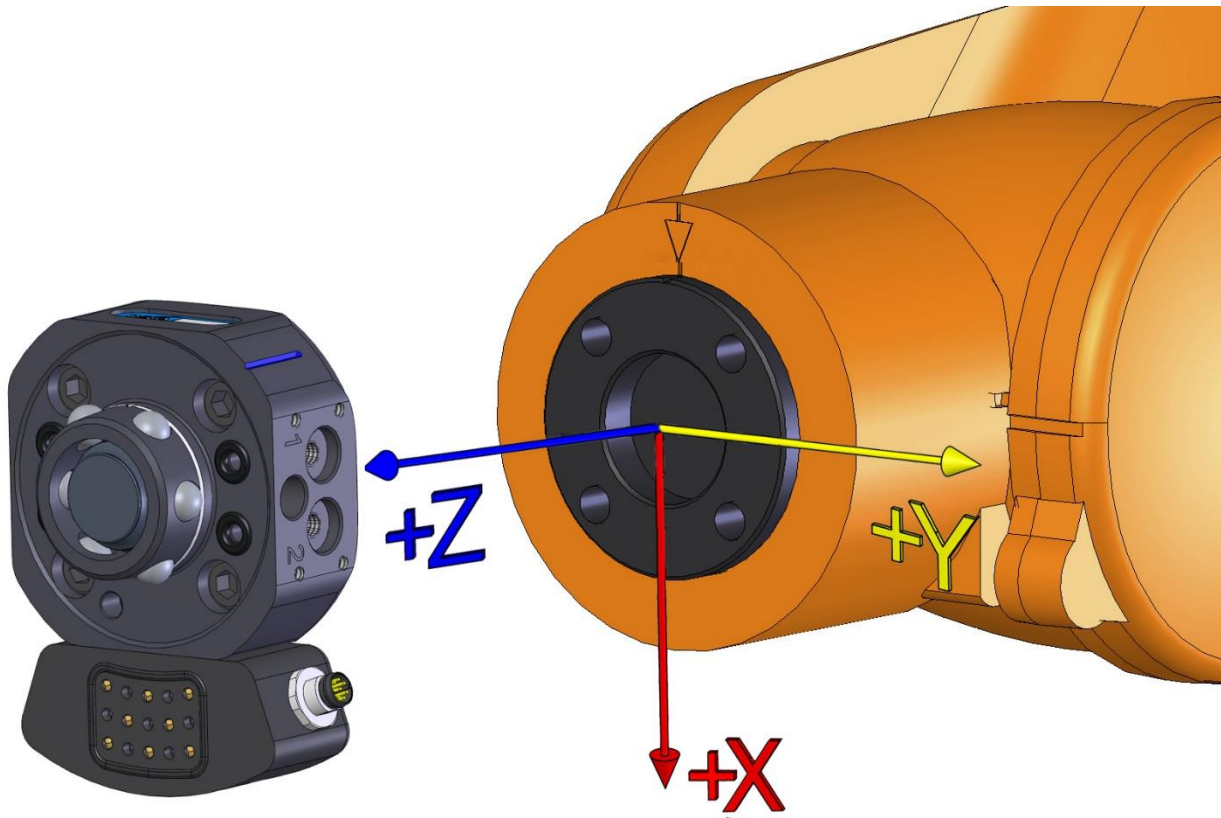

NOTE! For the CoboShift tool changers with or without tool attachment, the origin of the co-ordinate system is situated in the centre of the robot mounting flange.

2.1.2 CoboShift Tool Changer, ATC18-4. Article: P1181

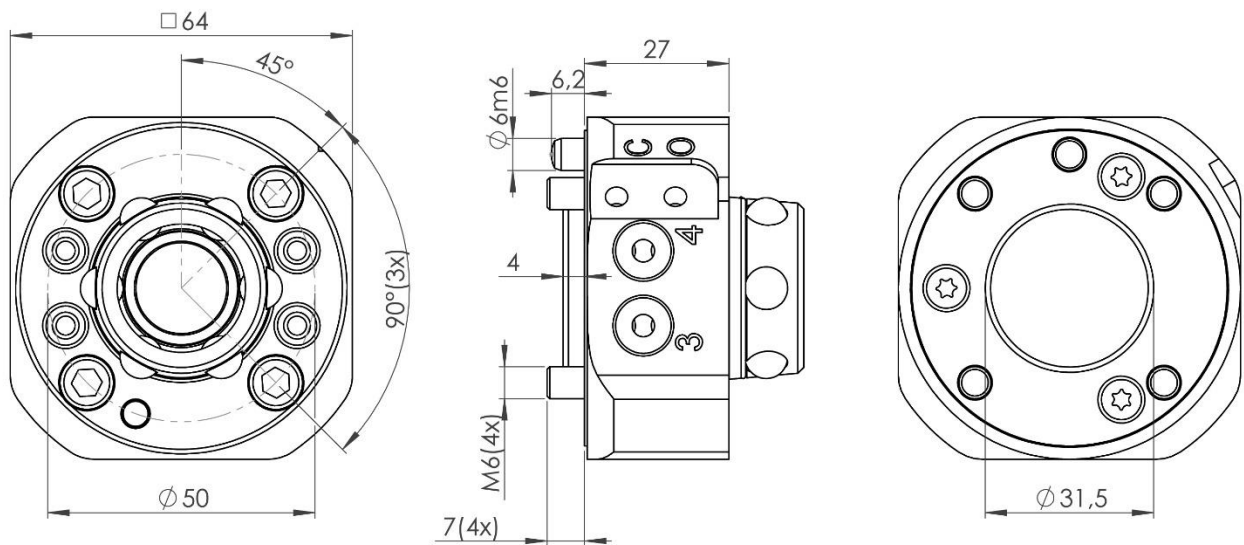

CoboShift tool changer P1181 transfers 4 pneumatic channels to the CoboShift tool attachment and has separate inlets for Open TC and Close TC. To be used together with P1182.

Technical data

Working temperature		+10°C – +50°C
Bolt pattern		ISO 9409-1-50-4-M6
Maximum tool load	Fz (static)	±180 N
Weight and centre of gravity (Z)		
	P1181	0.35 kg / 16 mm
	P1181+P1182	0,45 kg / 20 mm
Air channels	Pneumatic diagram	See section 2.1.14
	User channels, robot side	4 x M5 (150 l/min, max 10 bar)
	Dedicated channels (2 x M5)	Open TC marked O (6-10 bar) Close TC marked C (6-10 bar)
	Air quality	Oil-clean and waterless filtered air, with max 25µm particle content



NOTE! One position pin is included in the delivery. To be mounted, if required, by the customer in the Ø 5 mm hole.

2.1.3 CoboShift Tool Attachment, ATA18-4. Article: P1182

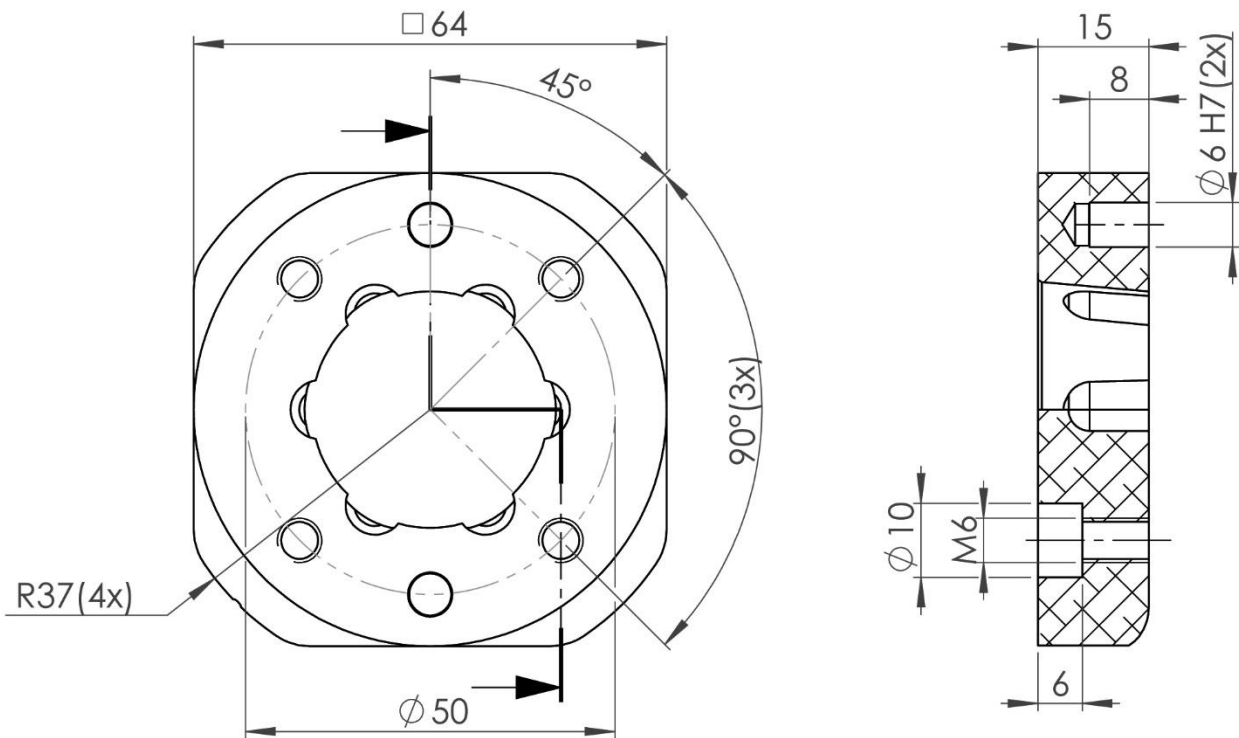

CoboShift tool attachment P1182 transfers 4 pneumatic channels to the tool. To be used together with P1181.

Technical data

Working temperature	+10°C – +50°C	
Bolt pattern	ISO 9409-1-50-4-M6	
Weight	0.10 kg	
Maximum tool load	Fz (static)	±180 N
Air channels	Connections, tool side	4 x M5



NOTE! Tools can be mounted to the tool attachment using four M6-screws, alternatively the tool attachment can be mounted to the tool using four M5-screws.

2.1.4 CoboShift Tool Changer with 8 electric signals, ATC18-4 8E.
Article: P1187

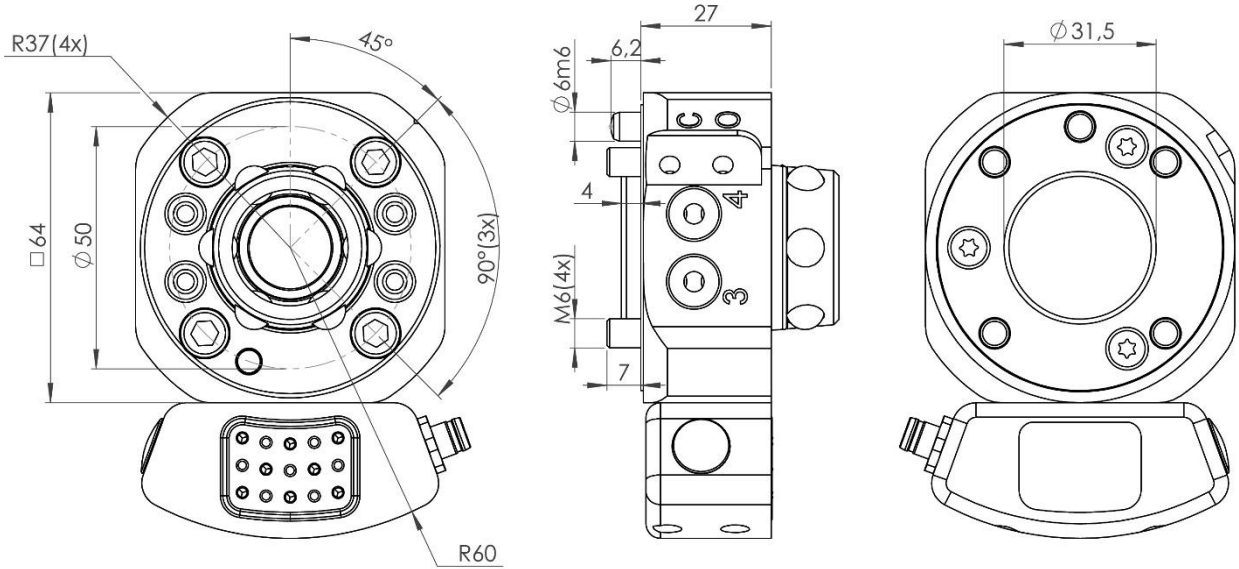

CoboShift tool changer P1187 transfers 4 pneumatic channels and 8 electrical signals to the CoboShift tool attachment and has separate inlets for Open TC and Close TC. To be used together with P1188.

Working temperature		+10°C – +50°C
Bolt pattern		ISO 9409-1-50-4-M6
Maximum tool load	Fz (static)	±180 N
Weight and centre of gravity (Z)		
P1187		0.41 kg / 16 mm
P1187+P1188		0,54 kg / 20 mm
Air channels	Pneumatic diagram	See section 2.1.14
	User channels, robot side Dedicated channels (2 x M5)	4 x M5 (150 l/min, max 10 bar) Open TC marked O (6-10 bar) Close TC marked C (6-10 bar)
	Air quality	Oil-clean and waterless filtered air, with max 25µm particle content
Electrical signals	Circuit diagram	E0185-087 (section 2.2.2)
	Total signals	8 x (1A, 30V)
	Connection, robot side	M8 8P (I2007)



NOTE! One position pin is included in the delivery. To be mounted, if required, by the customer in the Ø 5 mm hole.

2.1.5 CoboShift Tool Attachment with 8 electric signals, ATA18-4 8E.

Article: P1188

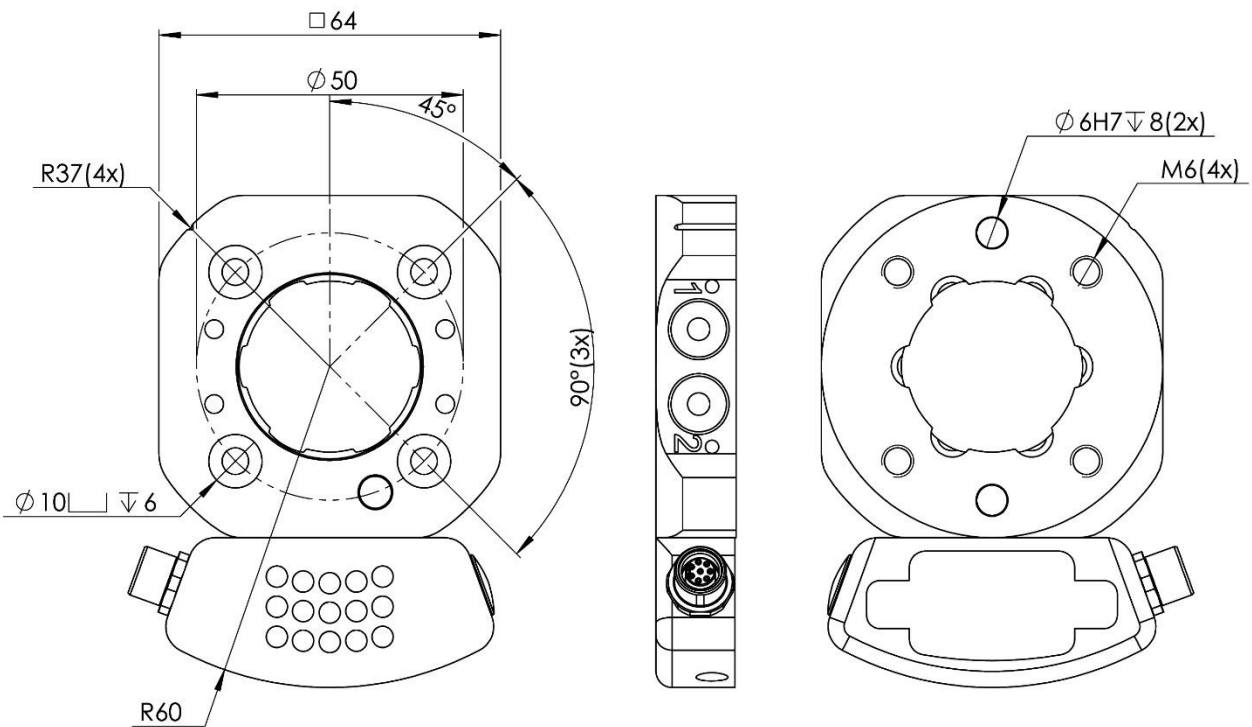

CoboShift tool attachment P1188 transfers 4 pneumatic channels and 8 electrical signals to the tool. To be used together with P1187.

Technical data

Working temperature		+10°C – +50°C
Bolt pattern		ISO 9409-1-50-4-M6
Weight		0.13 kg
Maximum tool load	Fz (static)	±180 N
Air channels	Connections, tool side	4 x M5
Electrical signals	Circuit diagram	E0185-088 (section 2.2.4)
	Total number of signals	8
	Connection, tool side	M8 8S (I1163)



NOTE! Tools can be mounted to the tool attachment using four M6-screws, alternatively the tool attachment can be mounted to the tool using four M5-screws.

2.1.6 CoboShift Tool Changer with 15 electric signals, ATC18-4 15E. Article: P1191

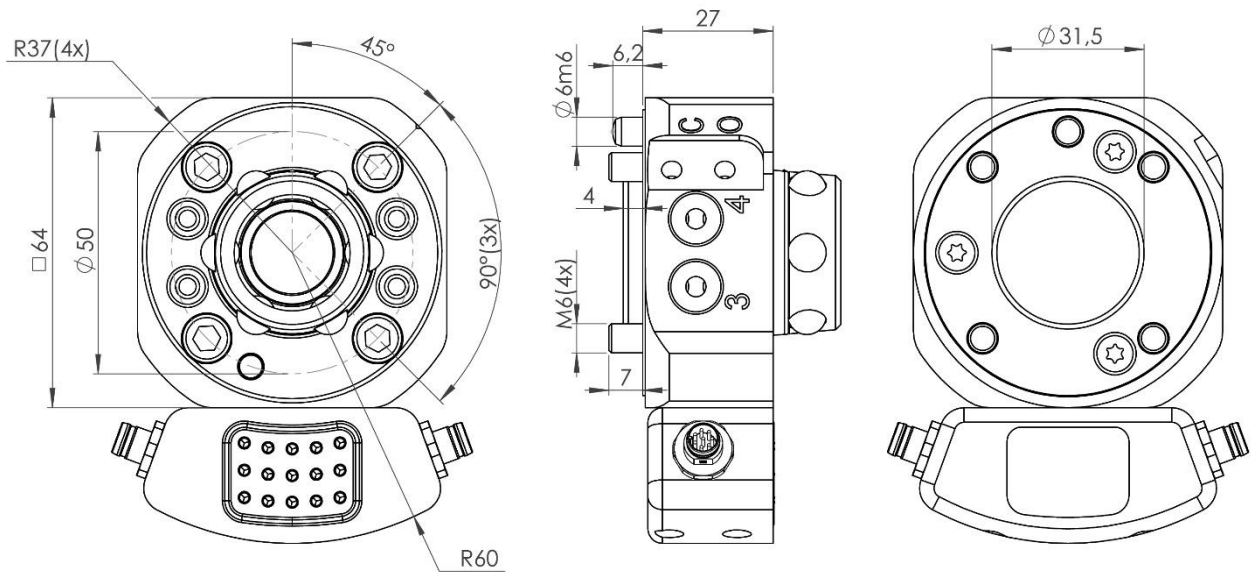

CoboShift tool changer P1191 transfers 4 pneumatic channels and 15 electrical signals to the CoboShift tool attachment and has separate inlets for Open TC and Close TC. To be used together with P1192.

Working temperature		+10°C – +50°C
Bolt pattern		ISO 9409-1-50-4-M6
Maximum tool load	Fz (static)	±180 N
Weight and centre of gravity (Z)		
	P1191	0.42 kg / 16 mm
	P1191+P1192	0,56 kg / 20 mm
Air channels	Pneumatic diagram	See section 2.1.14
	User channels, robot side	4 x M5 (150 l/min, max 10 bar)
	Dedicated channels (2 x M5)	Open TC marked O (6-10 bar) Close TC marked C (6-10 bar)
	Air quality	Oil-clean and waterless filtered air, with max 25µm particle content
Electrical signals	Circuit diagram	E0185-100 (section 2.2.6)
	Total signals	15 x (1A, 30V)
	Connection, robot side	2 x M8 8P (I2007)



NOTE! One position pin is included in the delivery. To be mounted, if required, by the customer in the Ø 5 mm hole.

2.1.7 CoboShift Tool Attachment with 15 electric signals, ATA18-4 15E. Article: P1192

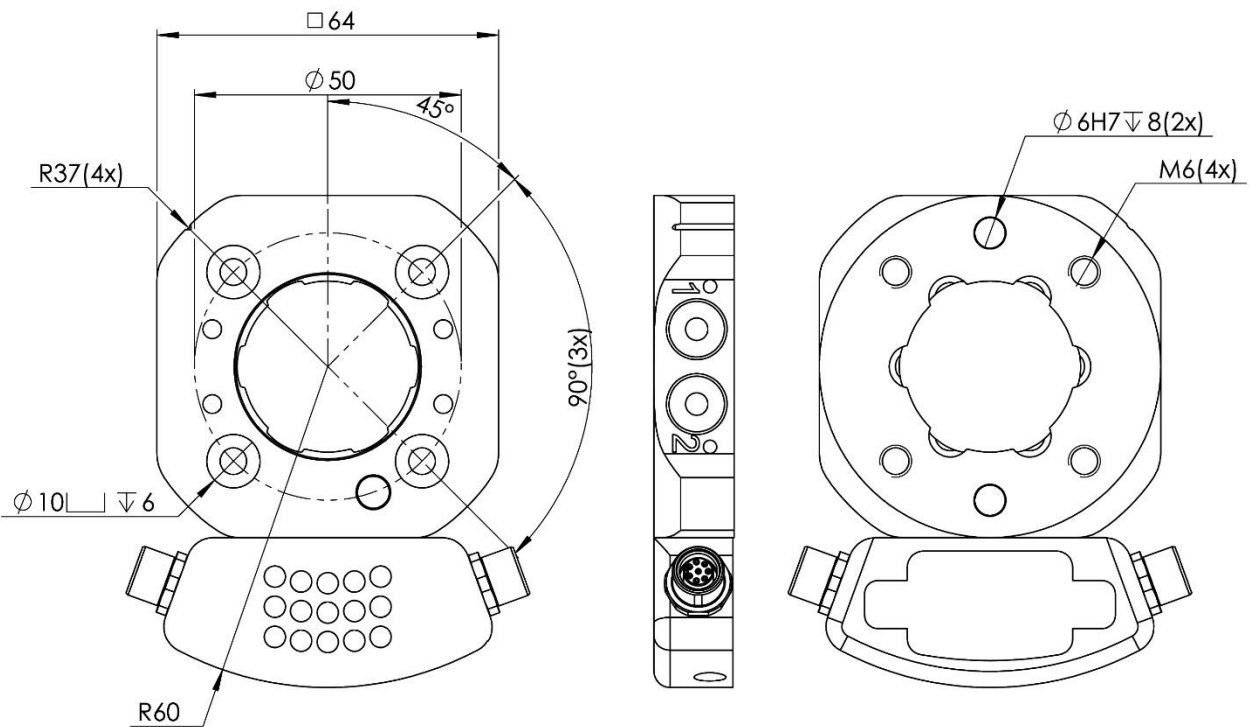

CoboShift tool attachment P1192 transfers 4 pneumatic channels and 15 electrical signals to the tool. To be used together with P1191.

Technical data

Working temperature		+10°C – +50°C
Bolt pattern		ISO 9409-1-50-4-M6
Weight		0.14 kg
Maximum tool load	Fz (static)	±180 N
Air channels	Connections, tool side	4 x M5
Electrical signals	Circuit diagram	E0185-101 (section 2.2.8)
	Total number of signals	15
	Connection, tool side	2 x M8 8S (I1163)



NOTE! Tools can be mounted to the tool attachment using four M6-screws, alternatively the tool attachment can be mounted to the tool using four M5-screws.

2.1.8 CoboShift Manual Tool Changer, MTC18-4. Article: P6018

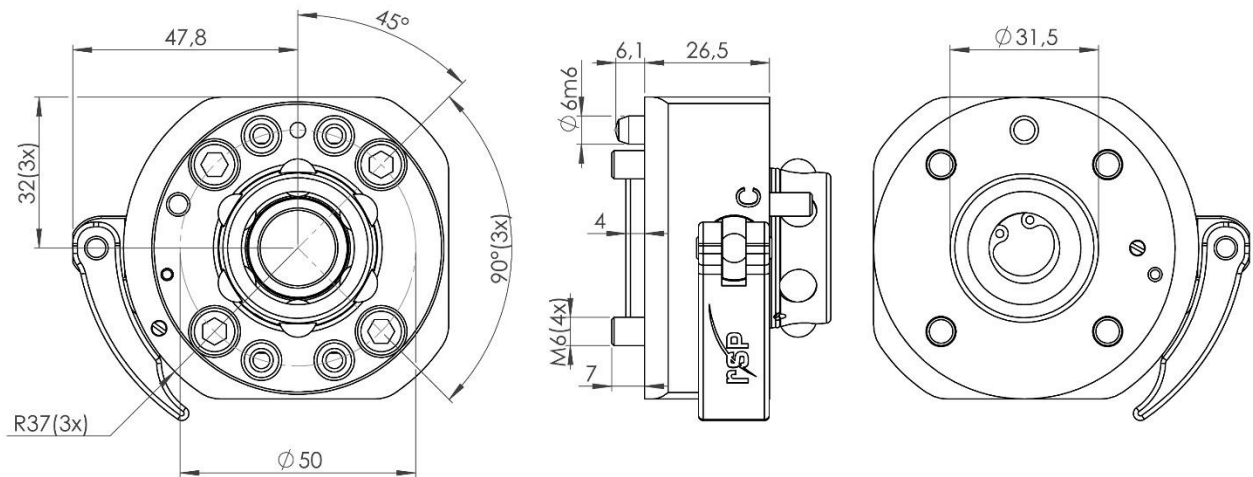

CoboShift manual tool changer P6018 transfers 4 pneumatic channels to the CoboShift tool attachment. To be used together with P6019.

Technical data

Working temperature		+10°C – +50°C
Bolt pattern		ISO 9409-1-50-4-M6
Maximum tool load	Fz (static)	±180 N
Weight and centre of gravity (Z)		
	P6018	0,41 kg / 16 mm
	P6018+ P6019	0,53 kg / 20 mm
Air channels	Pneumatic diagram User channels, robot side Air quality	See section 2.1.15 4 x M5 (150 l/min, max 10 bar) Oil-clean and waterless filtered air, with max 25µm particle content



NOTE! One position pin is mounted in the Ø 5 mm hole.

2.1.9 CoboShift Manual Tool Attachment, MTA18-4. Article: P6019

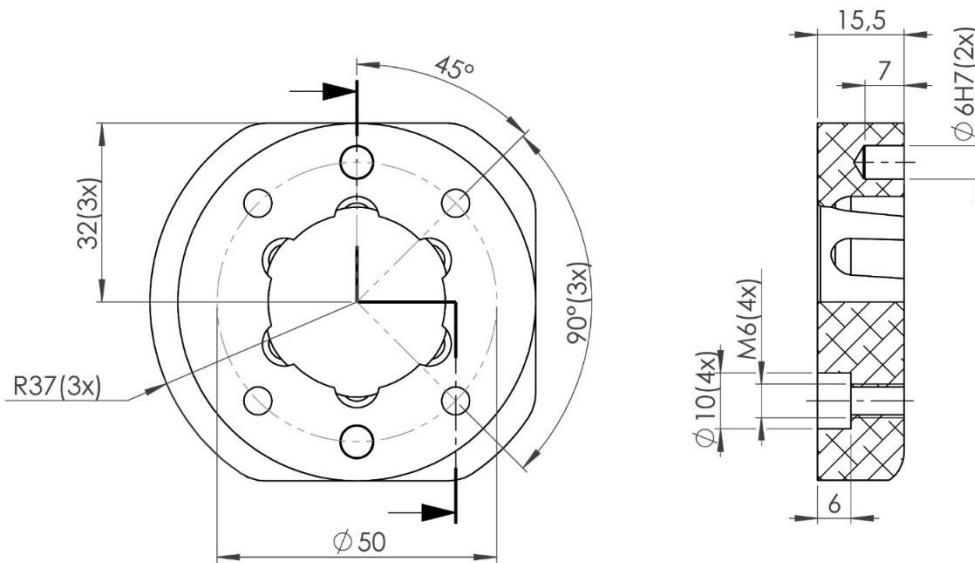

CoboShift manual tool attachment P6019 transfers 4 pneumatic channels to the tool. To be used together with P6018.

Technical data

Working temperature		+10°C – +50°C
Bolt pattern		ISO 9409-1-50-4-M6
Weight		0.12 kg
Maximum tool load	Fz (static)	±180 N
Air channels	Connections, tool side	4 x M5



NOTE! Tools can be mounted to the tool attachment using four M6-screws, alternatively the tool attachment can be mounted to the tool using four M5-screws.

2.1.10 CoboShift Manual Tool Changer with 8 electric signals, MTC18-4 8E. Article: P6020

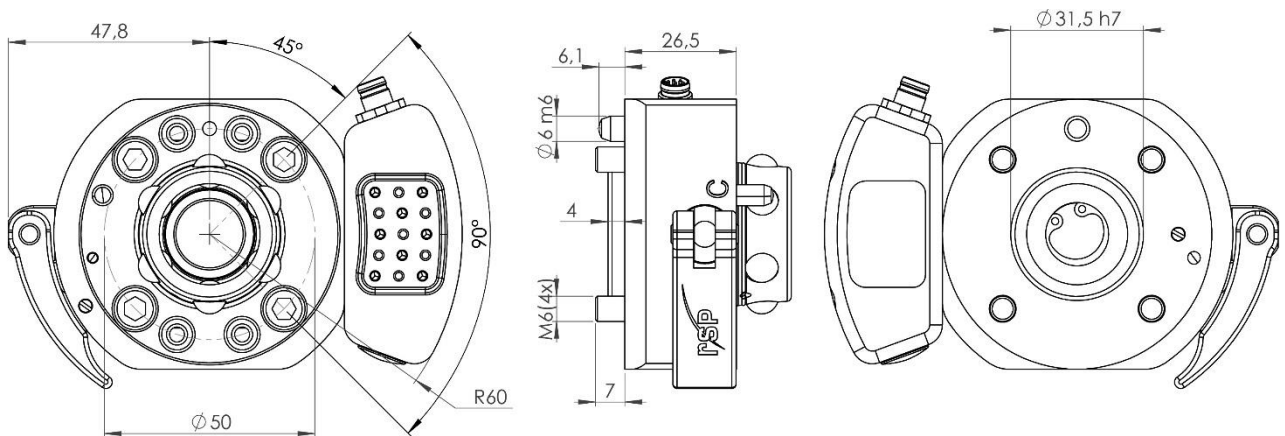

CoboShift manual tool changer P6020 transfers 4 pneumatic channels and 8 electrical signals to the CoboShift tool attachment. To be used together with P6021.

Technical data

Working temperature		+10°C – +50°C
Bolt pattern		ISO 9409-1-50-4-M6
Maximum tool load	Fz (static)	±180 N
Air channels	Pneumatic diagram	See section 2.1.15
	User channels, robot side	4 x M5 (150 l/min, max 10 bar)
	Air quality	Oil-clean and waterless filtered air, with max 25µm particle content
Electrical signals	Circuit diagram	E0185-087 (section 2.2.2)
	Total signals	8 x (1A, 30V)
	Connection, robot side	M8 8P (I2007)



NOTE! One position pin is mounted in the Ø 5 mm hole.

2.1.11 CoboShift Manual Tool Attachment with 8 electric signals, MTA18-4 8E. Article: P6021

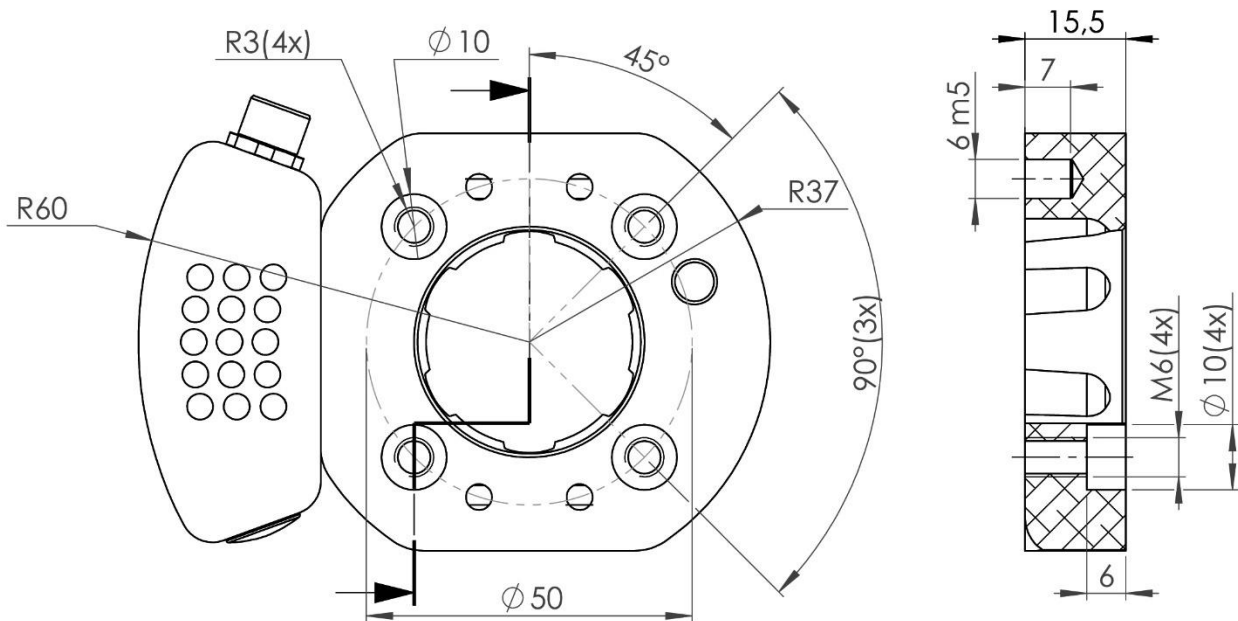

CoboShift manual tool attachment P6021 transfers 4 pneumatic channels and 8 electrical signals to the tool. To be used together with P6020.

Technical data

Working temperature		+10°C – +50°C
Bolt pattern		ISO 9409-1-50-4-M6
Weight		0.15 kg
Maximum tool load	Fz (static)	±180 N
Air channels	Connections, tool side	4 x M5
Electrical signals	Circuit diagram	E0185-088 (section 2.2.4)
	Total number of signals	8
	Connection, tool side	M8 8S (I1163)



NOTE! Tools can be mounted to the tool attachment using four M6-screws, alternatively the tool attachment can be mounted to the tool using four M5-screws.

2.1.12 CoboShift Manual Tool Changer with 15 electric signals, MTC18-4 15E. Article: P6022

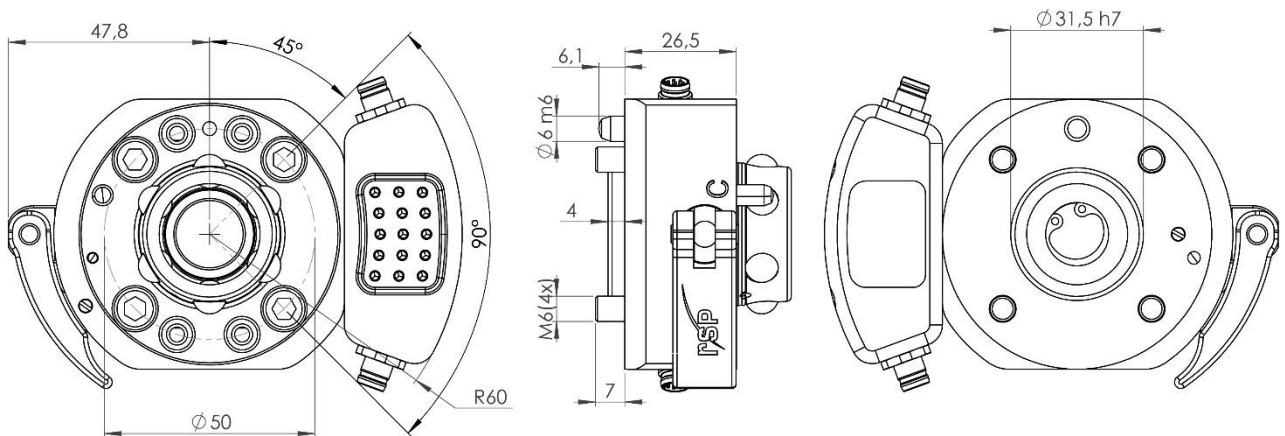

CoboShift manual tool changer P6022 transfers 4 pneumatic channels and 15 electrical signals to the CoboShift tool attachment. To be used together with P6023.

Technical data

Working temperature		+10°C – +50°C
Bolt pattern		ISO 9409-1-50-4-M6
Maximum tool load	Fz (static)	±180 N
Weight and centre of gravity (Z)		
	P6022	0.47 kg / 16 mm
	P6022+ P6023	0,62 kg / 19 mm
Air channels	Pneumatic diagram User channels, robot side Air quality	See section 2.1.15 4 x M5 (150 l/min, max 10 bar) Oil-clean and waterless filtered air, with max 25µm particle content
Electrical signals	Circuit diagram Total signals Connection, robot side	E0185-100 (section 2.2.6) 15 x (1A, 30V) 2 x M8 8P (I2007)



NOTE! One position pin is mounted in the Ø 5 mm hole.

2.1.13 CoboShift Manual Tool Attachment with 15 electric signals, MTA18-4 15E. Article: P6023

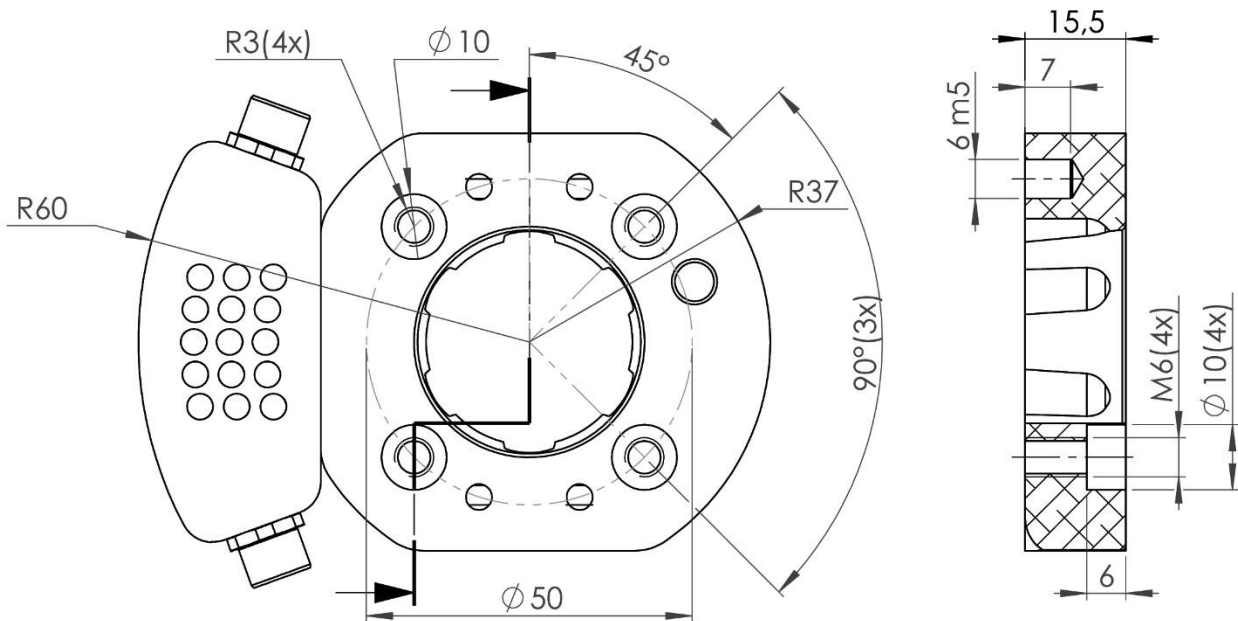

CoboShift manual tool attachment P6023 transfers 4 pneumatic channels and 15 electrical signals to the tool. To be used together with P6022.

Technical data

Working temperature		+10°C – +50°C
Bolt pattern		ISO 9409-1-50-4-M6
Weight		0.16 kg
Maximum tool load	Fz (static)	±180 N
Air channels	Connections, tool side	4 x M5
Electrical signals	Circuit diagram	E0185-101 (section 2.2.8)
	Total number of signals	15
	Connection, tool side	2 x M8 8S (I1163)



NOTE! Tools can be mounted to the tool attachment using four M6-screws, alternatively the tool attachment can be mounted to the tool using four M5-screws.

2.1.14 Pneumatic diagram for CoboShift tool changer ATC18/ATA18

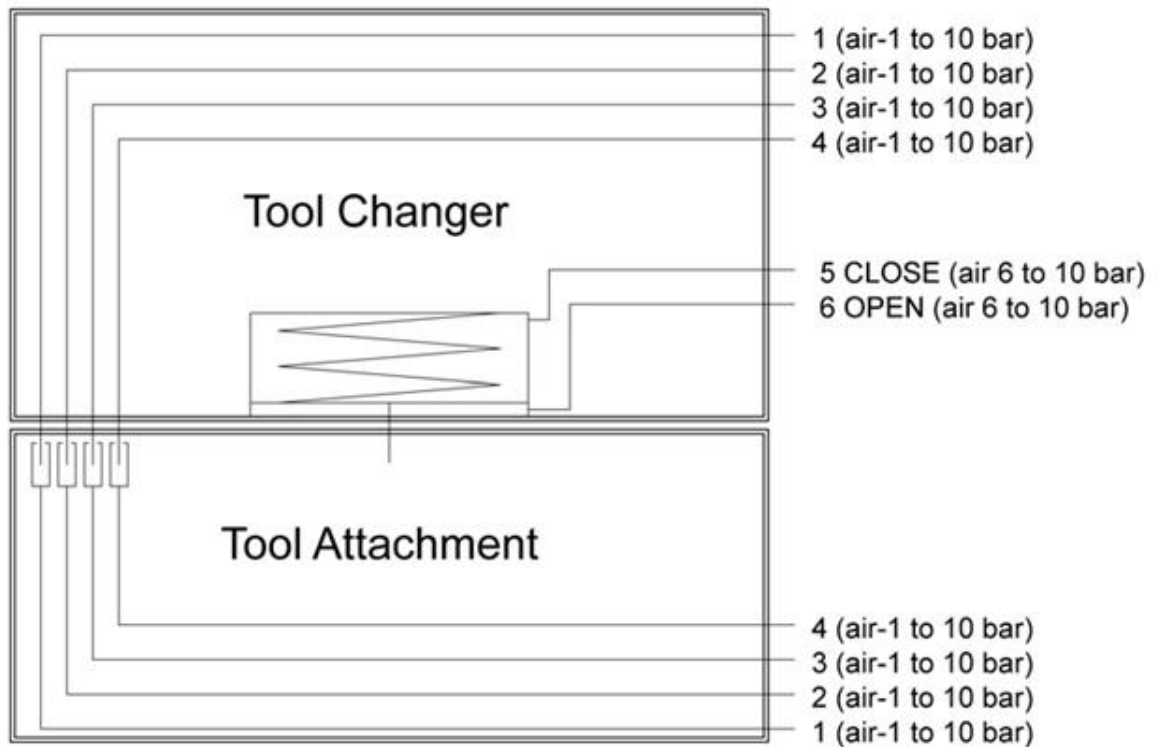

2.1.15 Pneumatic diagram for CoboShift manual tool changer MTC18/MTA18

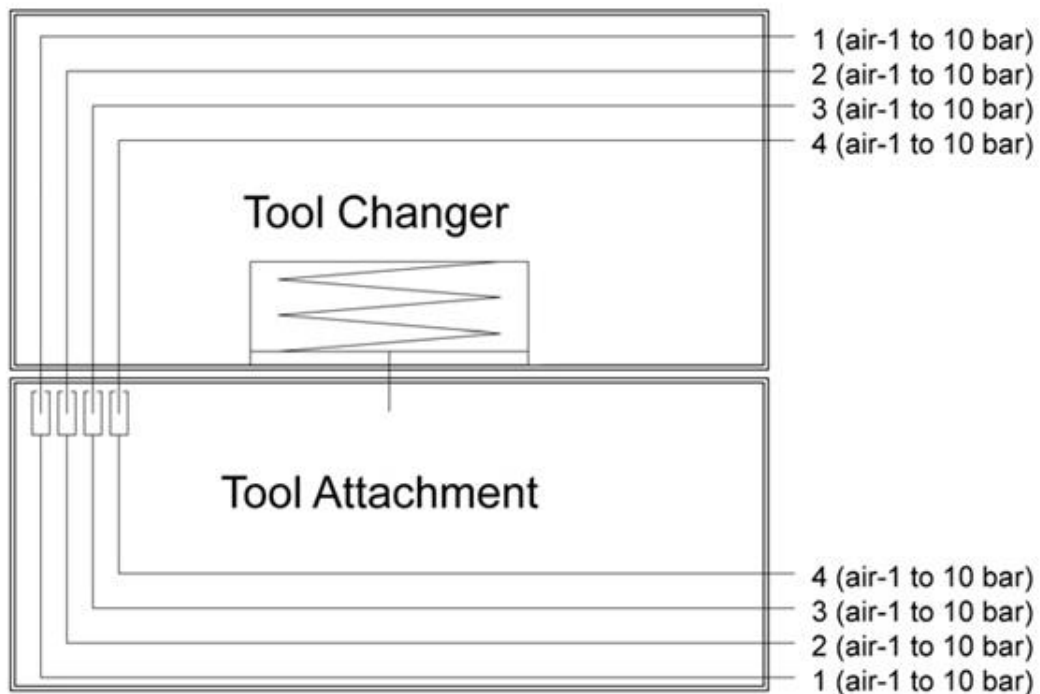

2.2 Options

2.2.1 CoboShift Signal Module, 8 signals, robot side. Article: P1179

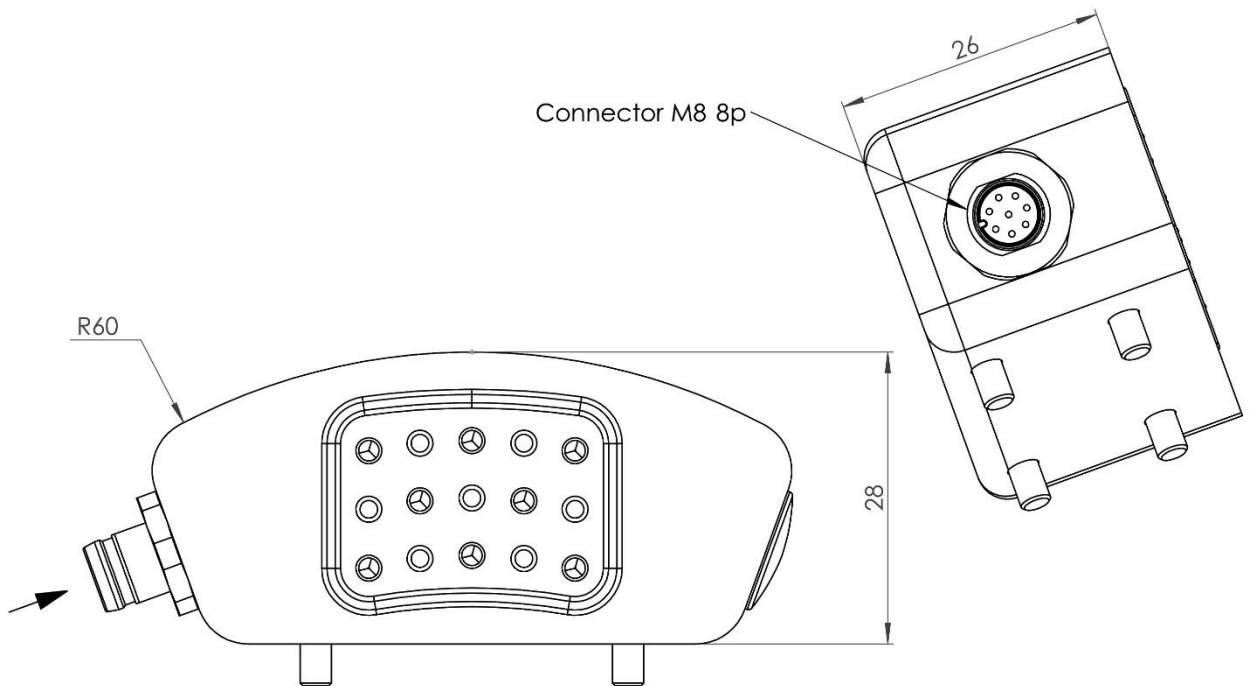

Transfers 8 electrical signal to the CoboShift tool attachment. Can be mounted at two different positions on the CoboShift tool changer. To be used with option P1180 on the tool attachment.

Technical data

Weight		0.05 kg
Electrical signals	Circuit diagram	E0185-087 (section 2.2.2)
	Total signals	8 x (1A, 30V)
	Connection, robot side	M8 8P (I2007)

2.2.2 Circuit diagram E0185-087 for P1179

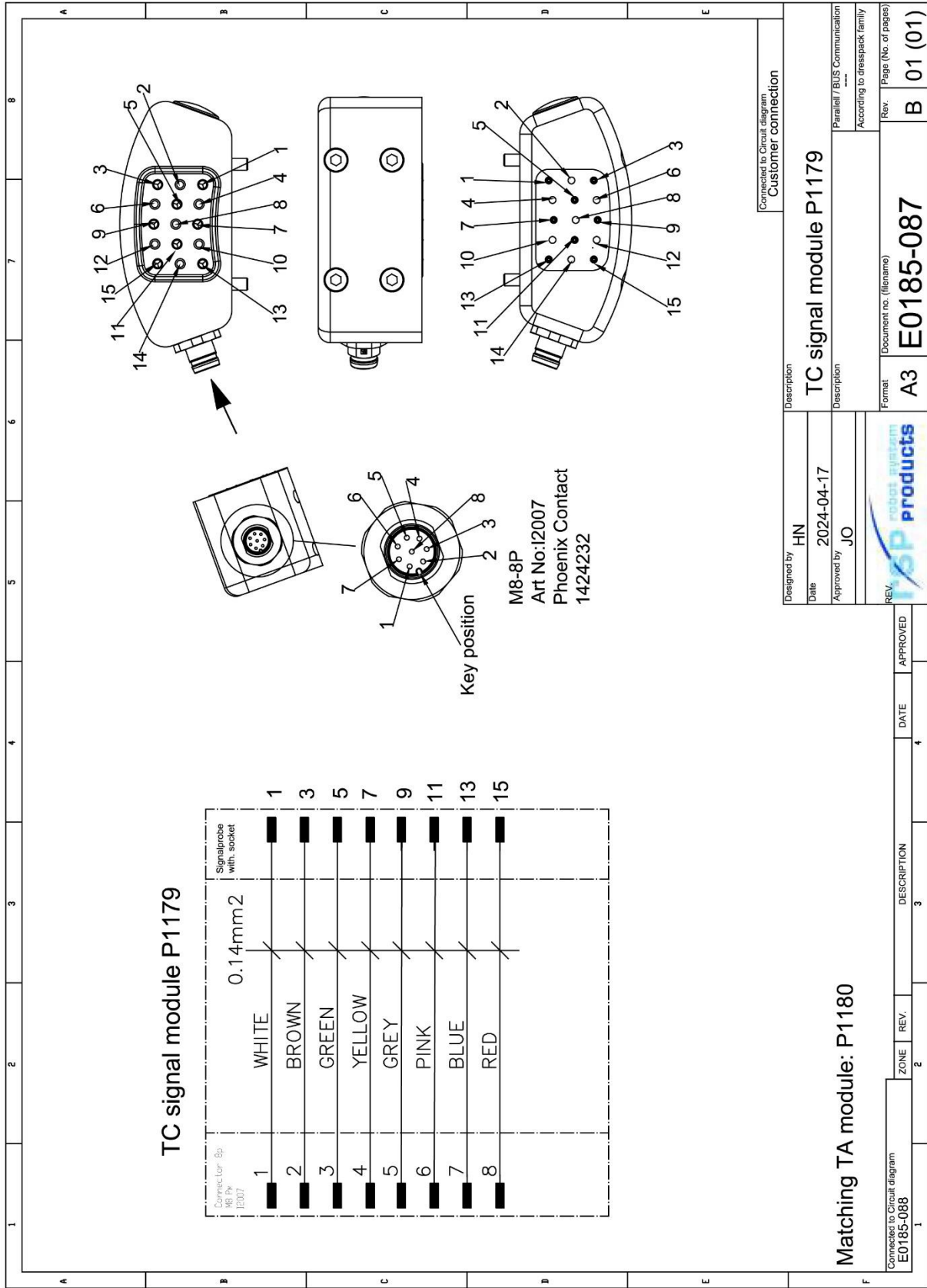

We reserve rights in this document and in the information contained therein.
Reproduction, use or disclosure to third parties without express authority
is strictly forbidden. Robot System Products

2.2.3 CoboShift Signal Module, 8 signals, tool side. Article: P1180

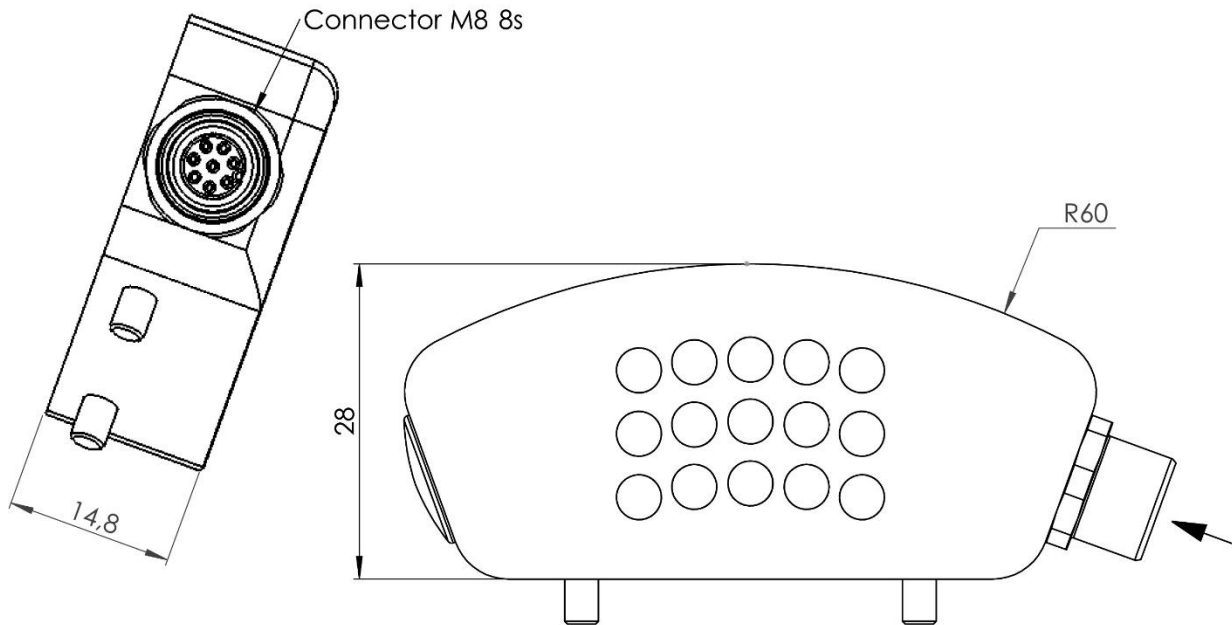

Transfers 8 electrical signal to the tool. Can be mounted at two different positions on the CoboShift tool attachment. To be used with option P1179 on the CoboShift tool changer.

Technical data

Weight		0.03 kg
Electrical signals	Circuit diagram	E0185-088 (section 2.2.4)
	Connection, tool side	M8 8S (I1163)

2.2.4 Circuit diagram E0185-088 for P1180

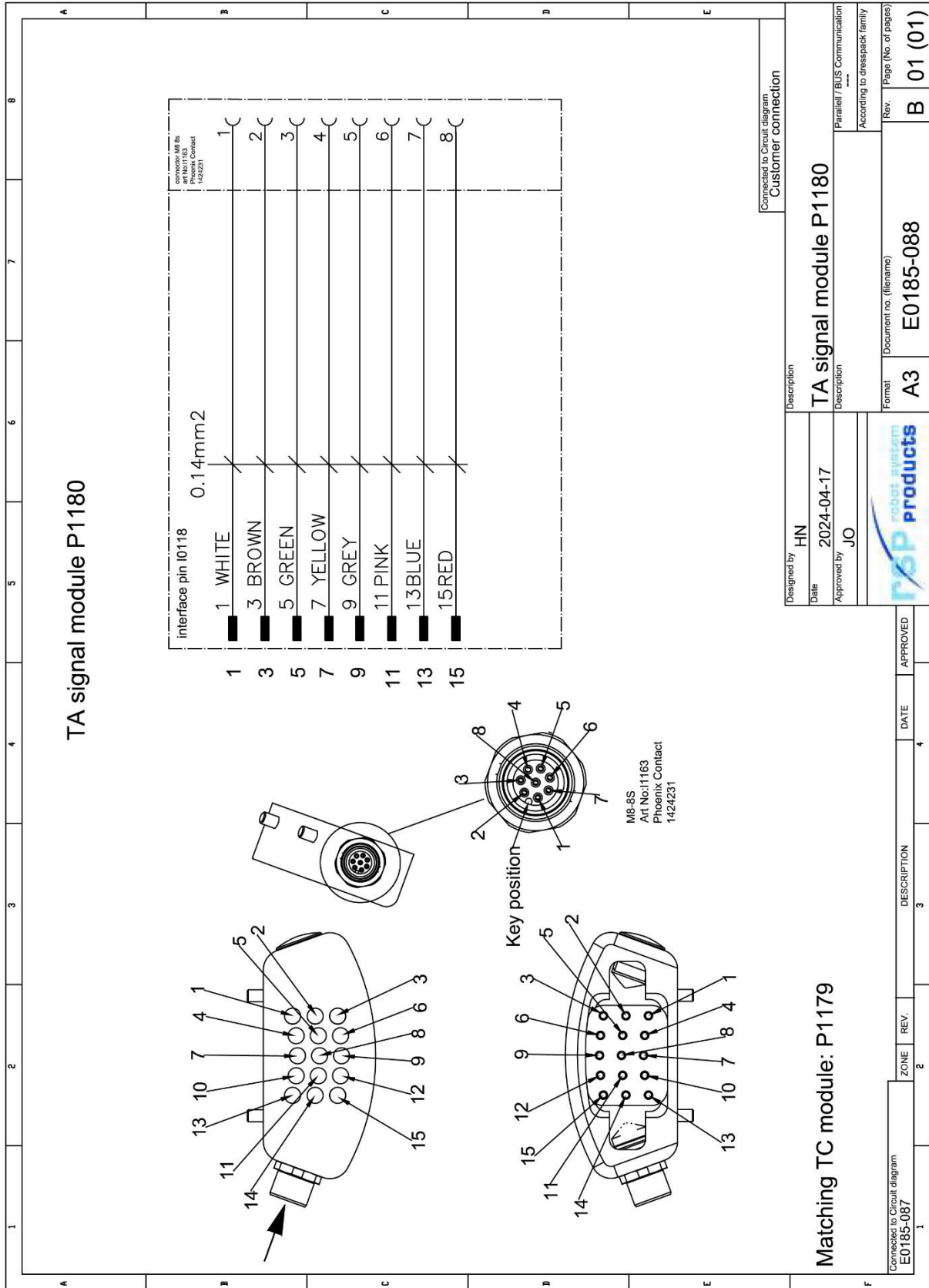

2.2.5 CoboShift Signal Module, 15 signals, robot side. Article: P1189

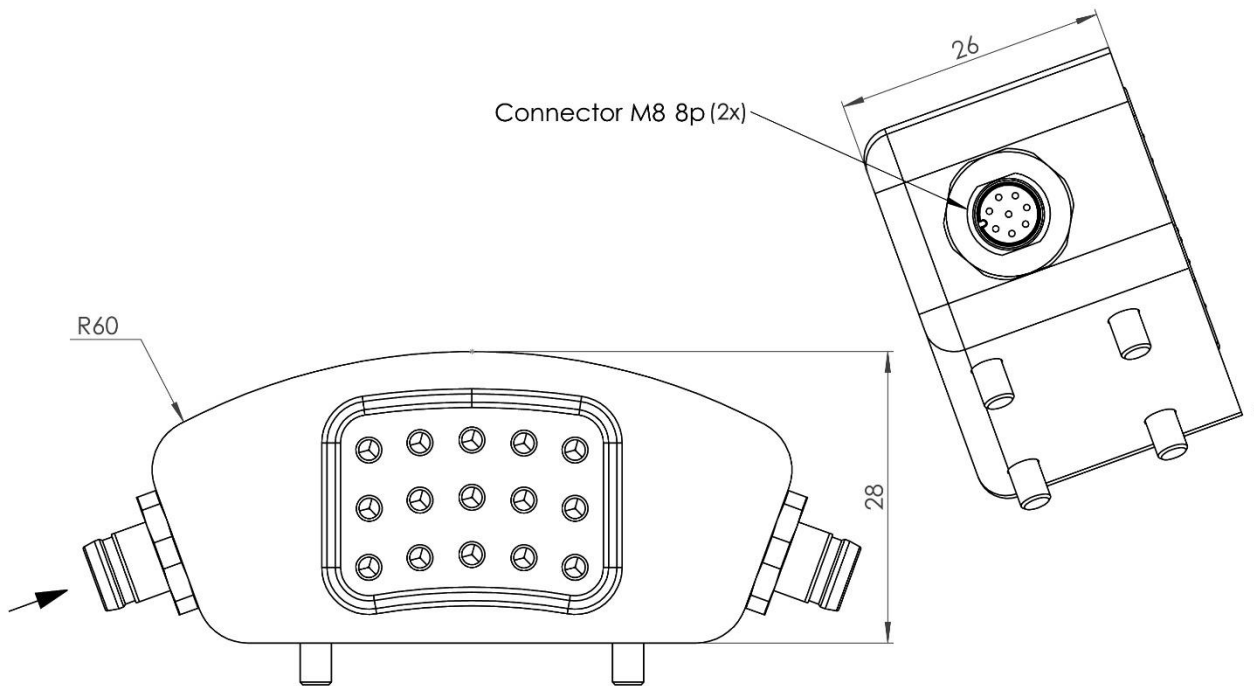

Transfers 15 electrical signal to the CoboShift tool attachment. Can be mounted at two different positions on the CoboShift tool changer. To be used with option P1190 on the tool attachment.

Technical data

Weight		0.06 kg
Electrical signals	Circuit diagram	E0185-100 (section 2.2.6)
	Total signals	15 x (1A, 30V)
	Connection, robot side	2 x M8 8P (I2007)

2.2.6 Circuit diagram E0185-100 for P1189

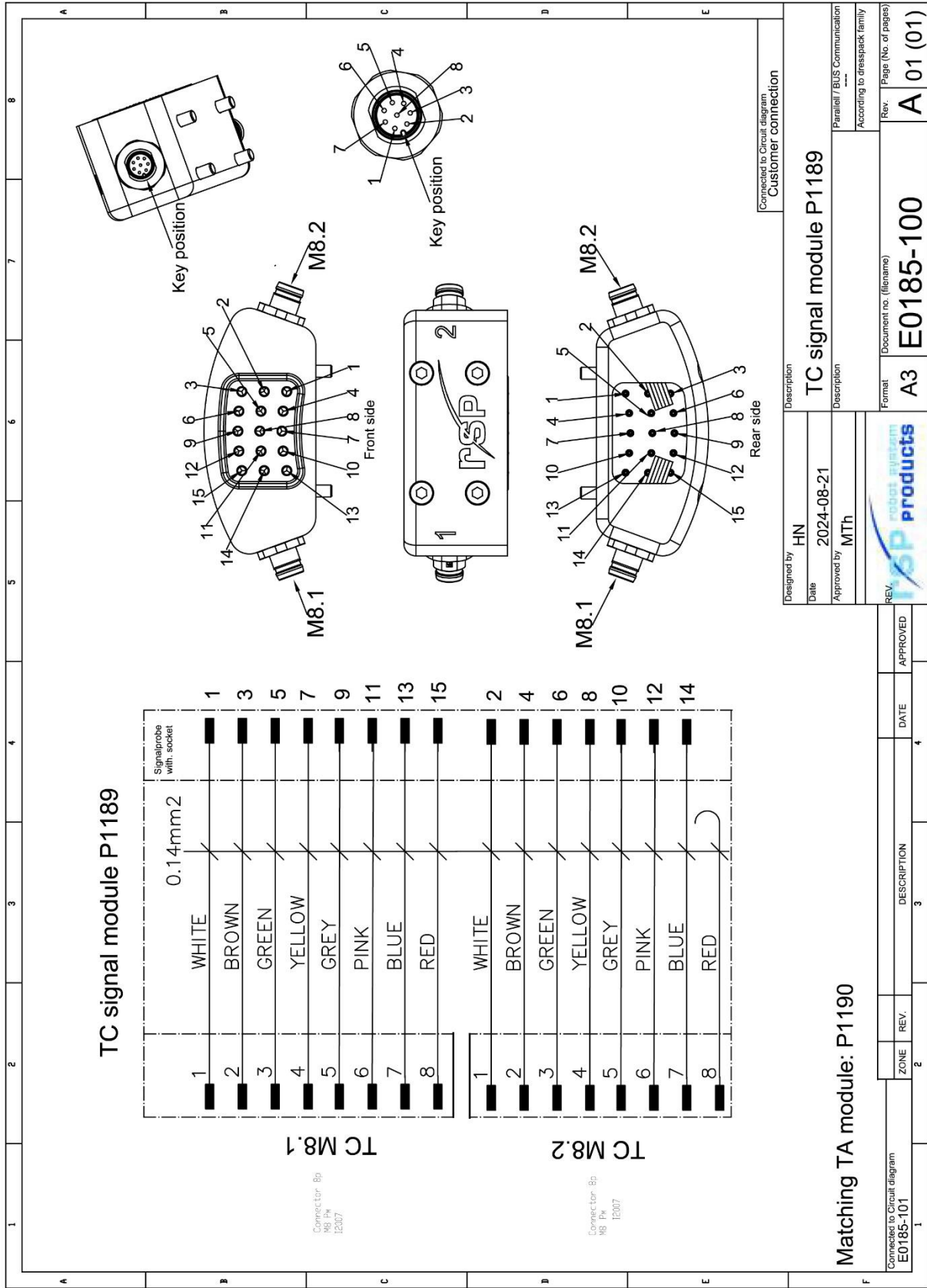

We reserve rights in this document and in the information contained therein. It is strictly forbidden to reproduce or disseminate this information without express authority from the manufacturer, Robot System Products.

2.2.7 CoboShift Signal Module, 15 signals, tool side. Article: P1190

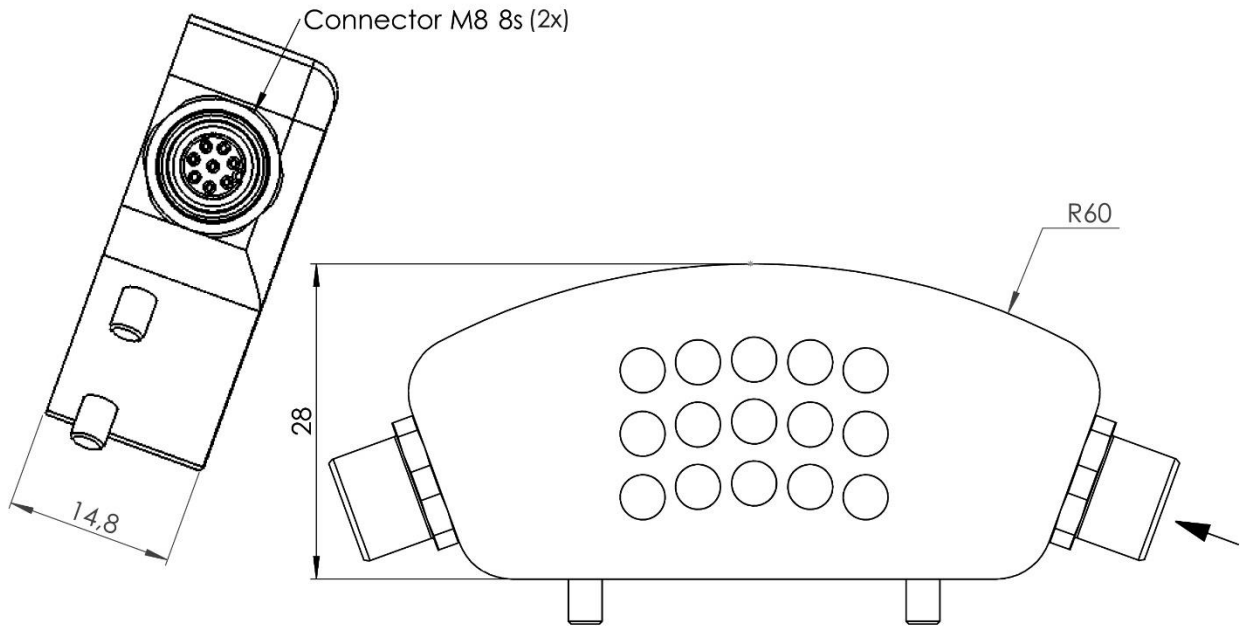

Transfers 15 electrical signal to the tool. Can be mounted at two different positions on the CoboShift tool attachment. To be used with option P1189 on the CoboShift tool changer.

Technical data

Weight		0.03 kg
Electrical signals	Circuit diagram	E0185-101 (section 2.2.8)
	Connection, tool side	2 x M8 8S (I1163)

2.2.9 CoboShift power and signal Module, 7 signals, robot side.
Article: P1193

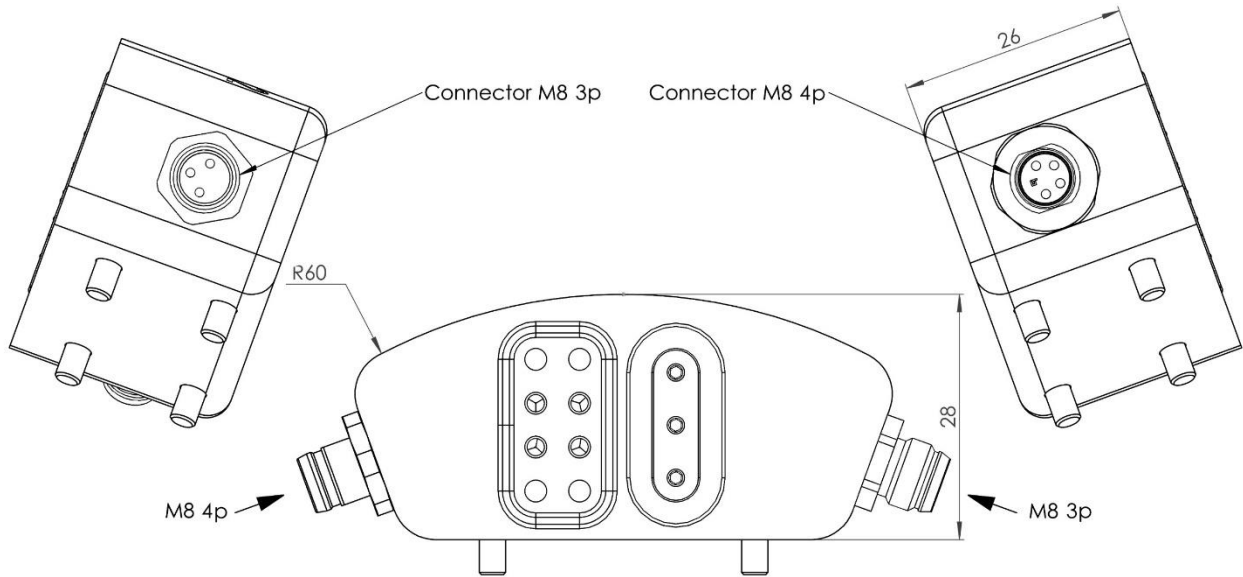

Transfers 4 electrical signals and 3 power signals to the CoboShift tool attachment. Can be mounted at two different positions on the CoboShift tool changer. To be used with option P1194 on the CoboShift tool attachment.

Technical data

Weight		0.07 kg
Electrical signals	Circuit diagram	E0185-103 (section 2.2.10)
	Total signals	4 x (1A, 30V), 3 x (4A, 60V)
	Connection, robot side	M8 4P (I2033), M8 3P (I1168)

2.2.10 Circuit diagram E0185-103 for P1193

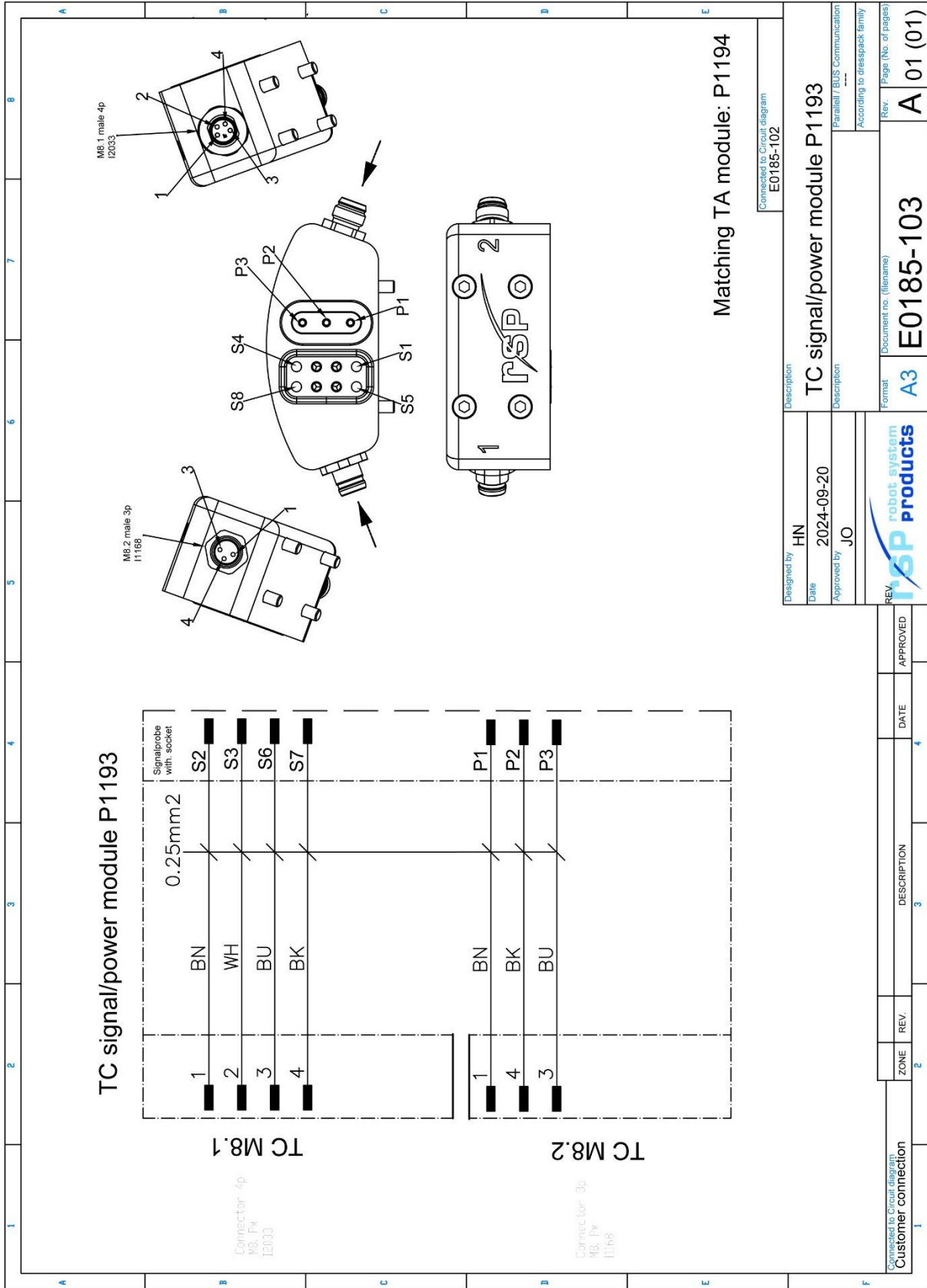

Matching TA module: P1194

Designed by	HN	Description	TC signal/power module P1193
Date	2024-09-20	Parallel / BUS Communication	According to dresspack family
Approved by	JO	Rev.	Page (No. of pages)
		Format	A3
REV. Document no. (filename)		E0185-103	
Connected to Circuit diagram		E0185-102	
ZONE	REV.	DESCRIPTION	DATE
1	2	3	4

2.2.11 CoboShift power and signal Module, 7 signals, tool side.
Article: P1194

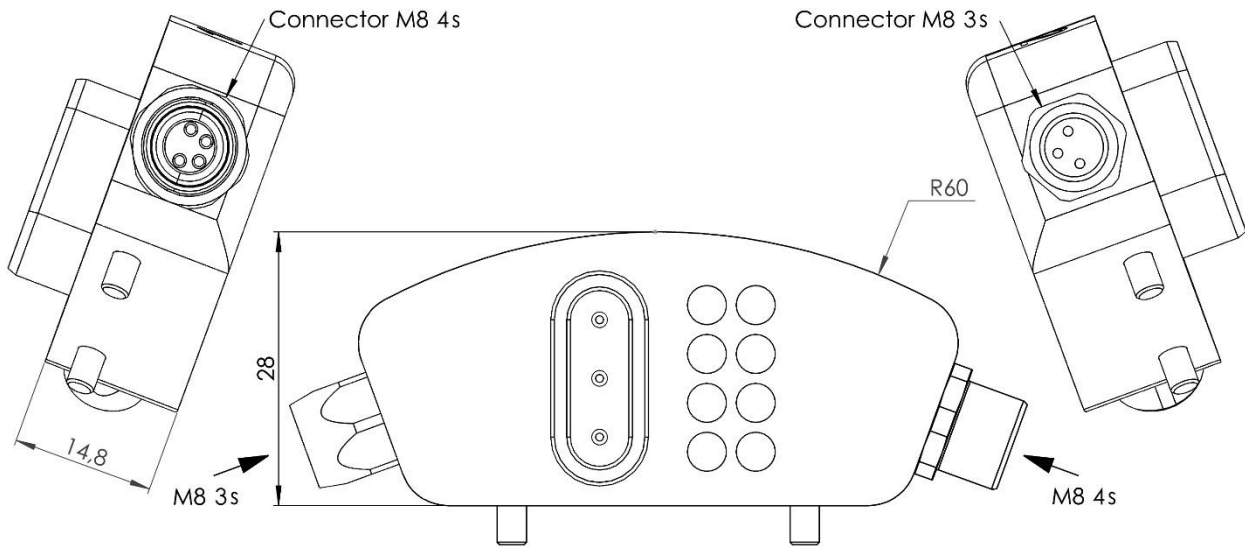

Transfers 4 electrical signals and 3 power signals to the tool. Can be mounted at two different positions on the CoboShift tool attachment. To be used with option P1193 on the CoboShift tool changer.

Technical data

Weight		0.05 kg
Electrical signals	Circuit diagram Connection, tool side	E0185-102 (section 2.2.12) M8 4S (I2034), M8 3S (I0029)

2.2.12 Circuit diagram E0185-102 for P1194

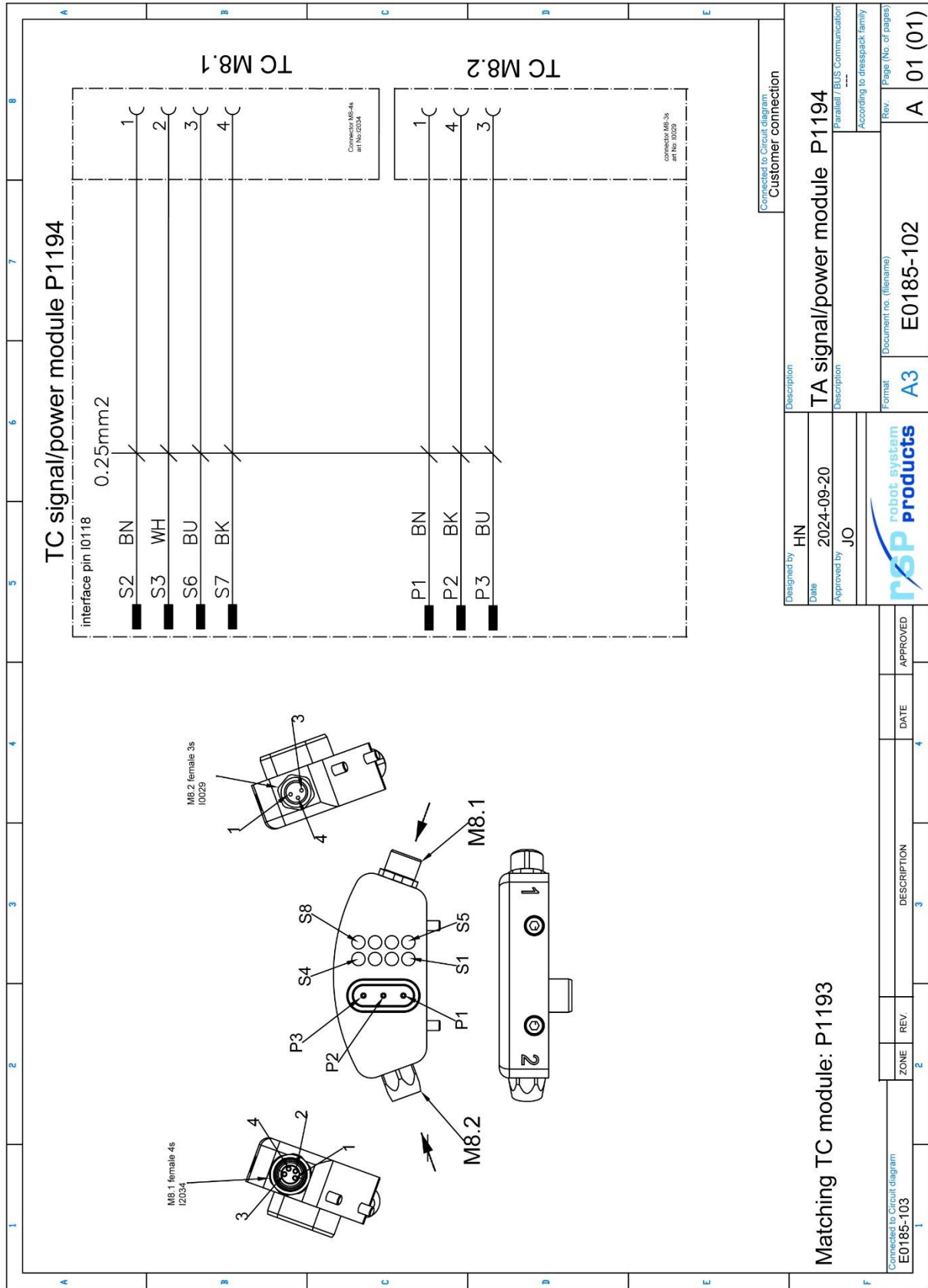

2.2.13 Tool stand kit for TA18-4. Article: P1185

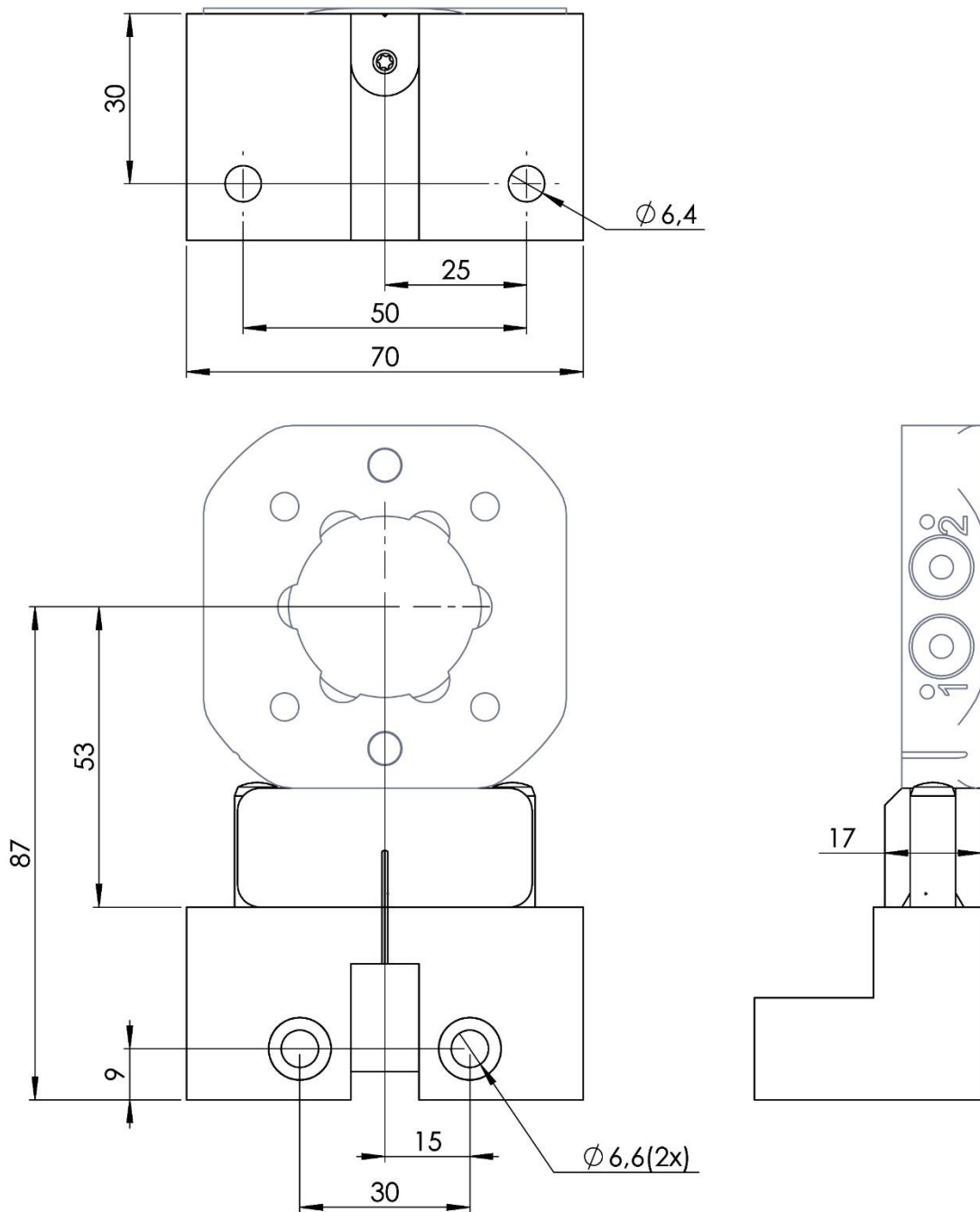

The tool stand kit P1185 is divided in two parts, one tool stand table (P1183) to be mounted on a tool stand and one bracket (P1184) to be mounted with a CoboShift tool attachment P1182, P1188 or P1192. The combination gives a robust tool stand solution for easy tool changing.

Technical data

Weight (bracket mounted on tool attachment)	0,12 kg
Maximum load	18 kg

3 SPARE PARTS

3.1 Part list for CoboShift tool changer P1181

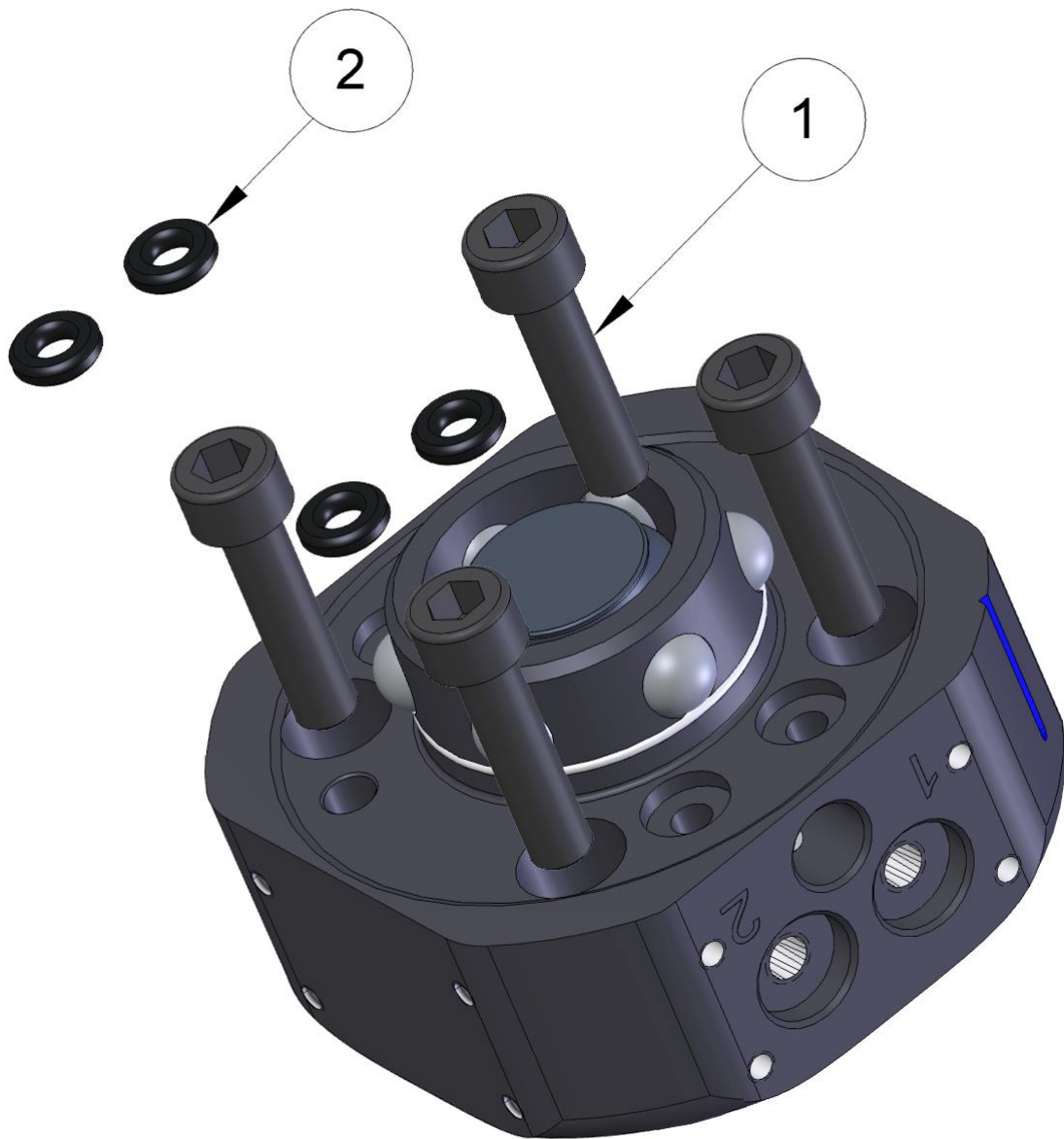

Item	Description	Part number	Wear part	Pcs
1	Fastening screw M6x25 (12.9)	MC6S 6x25 12.9		4
2	Air sealings	I0158	X	4

3.2 Part list for CoboShift tool changers P1187 and P1191

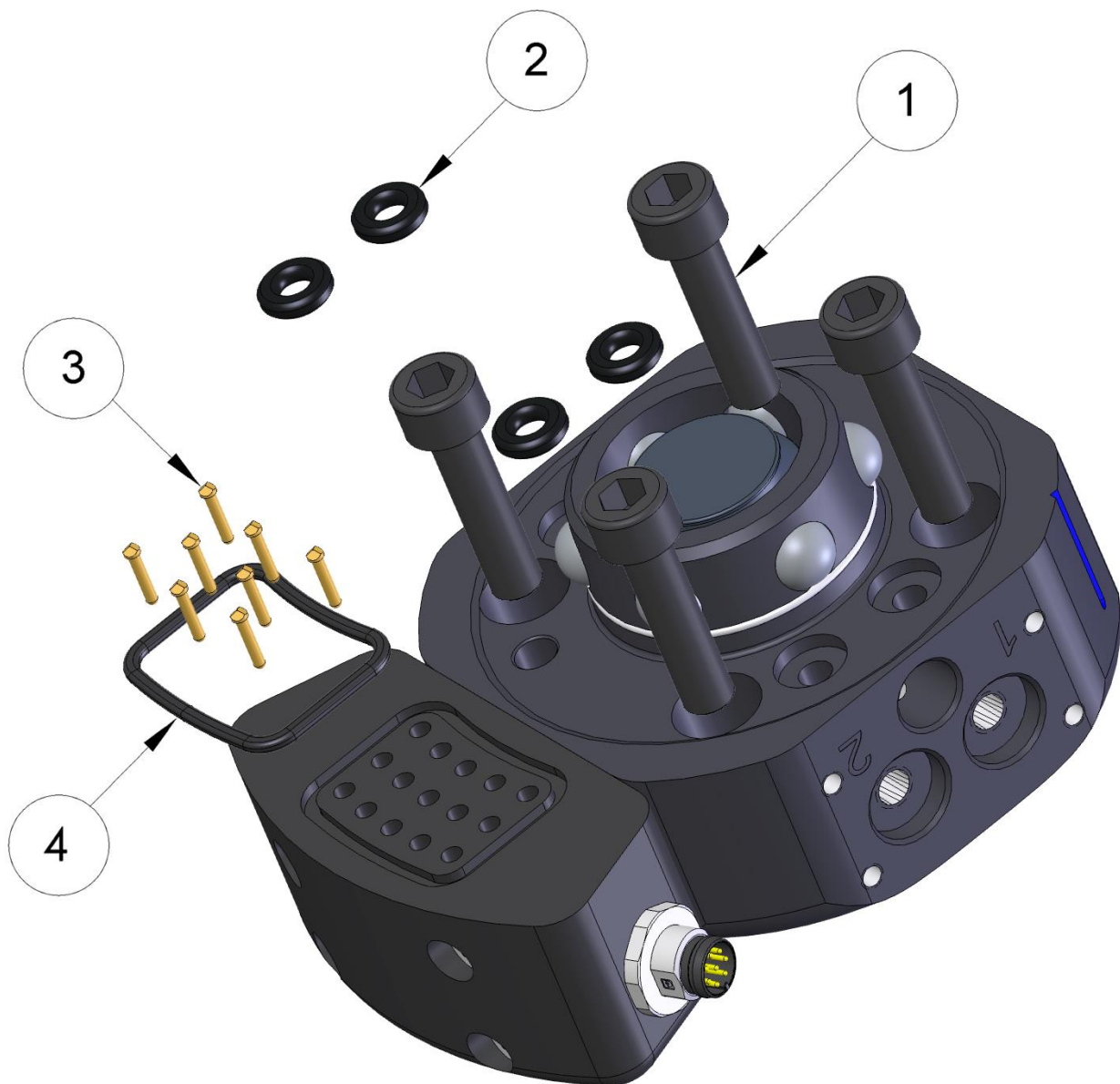

Item	Description	Part number	Wear part	Pcs
1	Fastening screw M6x25 (12.9)	MC6S 6x25 12.9		4
2	Air sealings	I0158	X	4
3	Spring loaded signal pin (P1187)	I0154	X	8
3	Spring loaded signal pin (P1191)	I0154	X	15
4	O.ring	I1945	X	1

3.3 Part list for CoboShift manual tool changer P6018

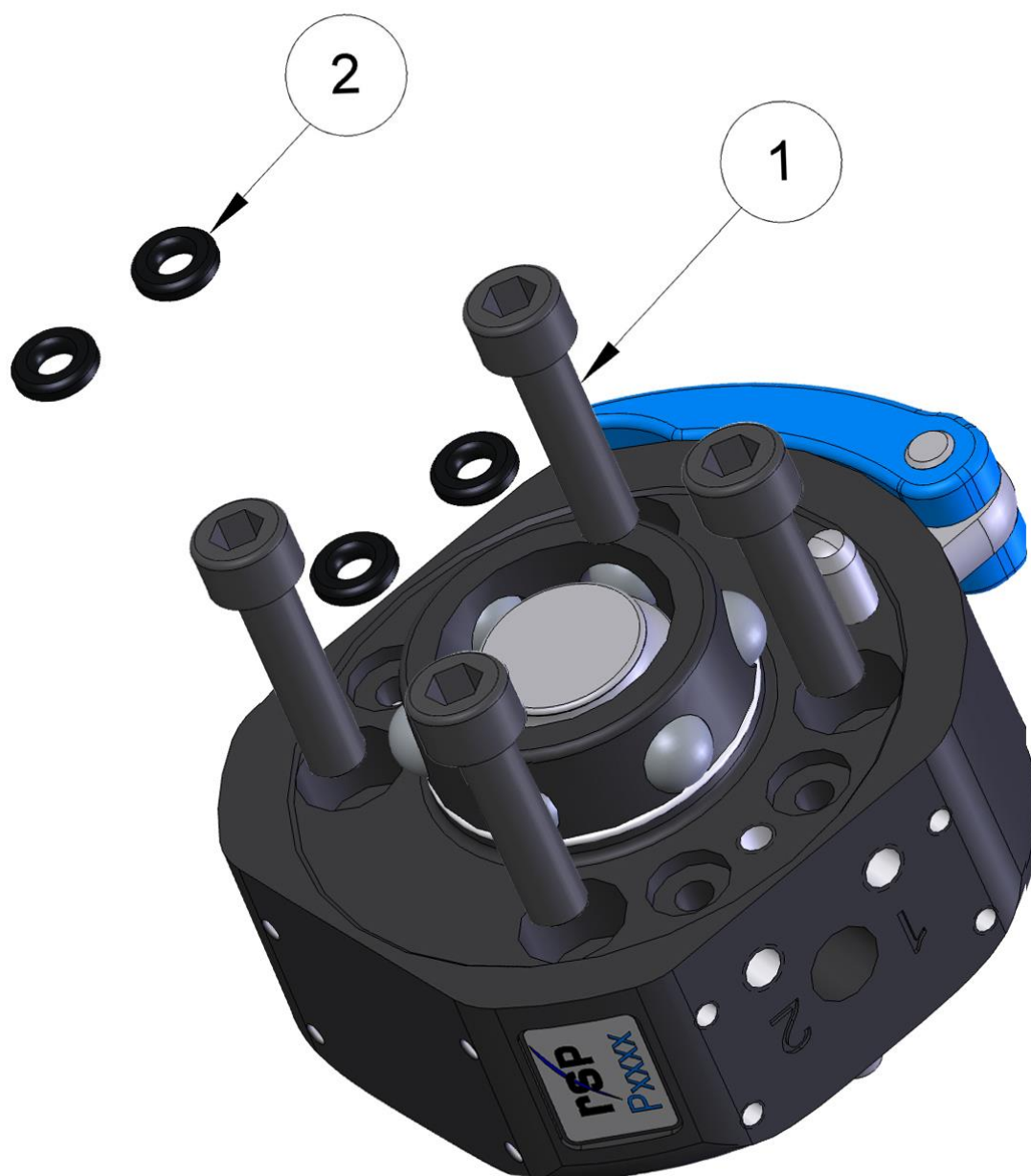

Item	Description	Part number	Wear part	Pcs
1	Fastening screw M6x25 (12.9)	MC6S 6x25 12.9		4
2	Air sealings	I0158	X	4

3.4 Part list for CoboShift manual tool changers P6020 and P6022



Item	Description	Part number	Wear part	Pcs
1	Fastening screw M6x25 (12.9)	MC6S 6x25 12.9		4
2	Air sealings	I0158	X	4
3	Spring loaded signal pin (P6020 only)	I0154	X	8
3	Spring loaded signal pin (P6022 only)	I0154	X	15
4	O.ring	I1945	X	1

3.5 Part list for CoboShift signal module P1179 and P1189



Item	Description	Part number	Wear part	Pcs
1	Spring loaded signal pin (P1179)	I0154	X	8
1	Spring loaded signal pin (P1189)	I0154	X	15
2	O.ring	I1945	X	1

3.6 Part list for CoboShift signal module P1193



Item	Description	Part number	Wear part	Pcs
1	Spring loaded signal pin	I0154	X	4
2	O.ring	I0776	X	1

