

Technical Description

Swivel tool changer STC20

M0115-1

Tool changers | Swivels | **Swivel tool changers** | Grippers | Hose packages | Valve units | Tool systems



The information in this document is subject to change without prior notice and should not be regarded as an undertaking from Robot System Products AB. Robot System Products AB assumes no responsibility for errors that may occur in this document.

Robot System Products AB bears no responsibility for damage that is incurred by the use of this document, or the software or hardware described in this document.

The document, or parts of it, may not be reproduced or copied without prior permission from Robot System Products AB. It may neither be imparted to a third party, nor otherwise be used without authorization. Infringement hereof will be subject to action in accordance with the applicable laws.

Further copies of this document can be obtained from Robot System Products AB at current prices.

© Robot System Products AB

Robot Systems Products AB
Isolatorvägen 4
SE-721 37 Västerås
Sweden

CONTENTS

1 INTRODUCTION	5
1.1 RSP swivel tool changer.....	6
1.2 Documents.....	6
1.3 Wear parts.....	6
1.4 Complementary Equipment.....	6
2 TECHNICAL SPECIFICATIONS	7
2.1 Description of swivel tool changers and tool attachments.....	7
2.1.1 Coordinate System Definition.....	8
2.1.2 Swivel with tool changer STC20-4. Article: P0106A.....	9
2.1.3 Tool attachment TA20-4, Article: P0102.....	10
2.1.4 Tool attachment TA20-4 steel, Article: P0123.....	11
2.1.5 Swivel with tool changer STC20-4E. Article: P0108A.....	12
2.1.6 Tool attachment TA20-4E, Article: P0109.....	13
2.1.7 Tool attachment TA20-4E steel, Article: P0125.....	14
2.1.8 Pneumatic diagram.....	15
2.1.9 Circuit diagram E0208-001 for P0108A with P0109/P0125.....	16
2.2 Options for swivel tool changer.....	17
2.2.1 Robot adaptation kits.....	17
2.2.2 Tool Identification.....	17
2.2.3 Limitation of Robot movements.....	17
2.2.4 Tool stand kit 20. Article: P0142.....	18
3 SPARE PARTS	19
3.1 Part list for swivel tool changer P0106A and P0108A.....	19

1 INTRODUCTION

Robot System Products is a front-rank provider of peripheral products for high performance robot applications. We provide complete system solutions for your robot installations, aiming to improve your productivity with the most reliable and cost-effective tooling on the market. Continuously we explore emerging technologies, working with leading edge design.

Robot System Products has a wide range of standard robot peripheral products:

- Tool changers
- Swivels
- Swivel tool changers
- CiRo
- Grippers
- Hose Packages
- Valve units
- Tool systems
- Tool parking systems

Robot System Products' tool changers are constructed to maximize the flexibility and reliability of your robot fleet. Through our patented locking device TrueConnect™ robustness and high safety are combined with low weight and compactness. With our swivels compressed air, water, electrical and data signals as well as weld and servo power are transferred to your tools with robot motion capabilities fully maintained. Our swivel tool changers unite the TrueConnect™ mechanism with our swivel technology, combining the best out of the two technologies. With RSP's cost-effective CiRo, cables and hoses can be freely selected with high robot flexibility maintained, and space requirements reduced. Our integrated tool systems are delivered as complete plug-and-play solutions designed for quick and simple installation.

Robot System Products' product lines are available for all major robot brands and come with complete documentation. 3D-models for simulation are available for download at: www.rsp.eu.com.

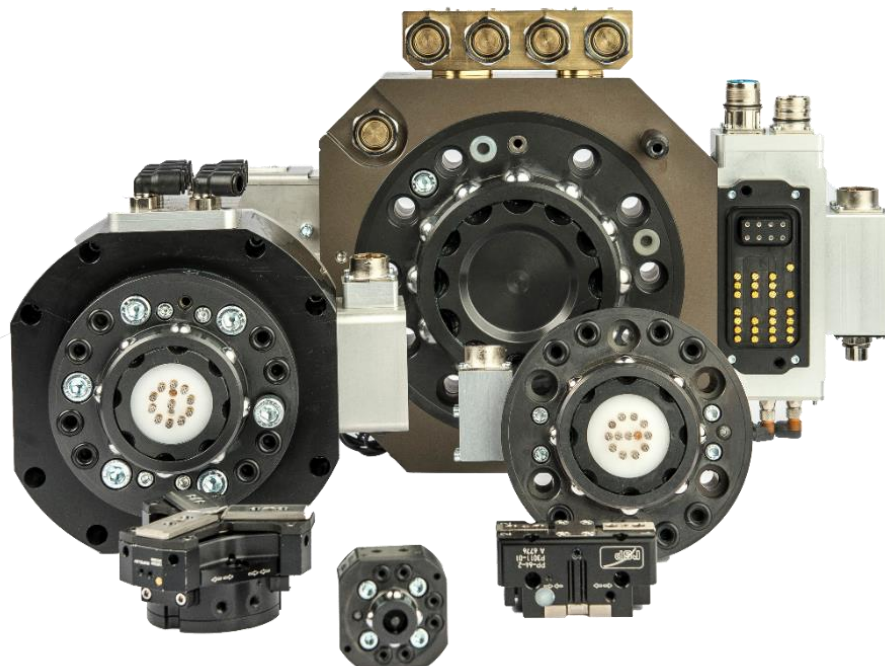

1.1 RSP swivel tool changer

The Robot System Products' swivel tool changer integrates the advantages of swivels and tool changers into one single product maximizing the flexibility and productivity of the robot.

Our tool changer technology enables robots to handle and switch between multiple tools. The principle behind the patented locking device TrueConnect™ is that load is distributed uniformly through pressing locking balls into spherical grooves in the tool attachment. With TrueConnect™ the play is a minimum and the position repeatability is practically absolute through the lifespan. In consequence substantially larger positional deviations are accepted when docking, A built-in spring ensures that the tool remains in place in the swivel tool changer even if the air pressure drops.

When using a swivel tool changer compressed air and electric signals will be directly available at the tool without loose, hanging cables and hoses which has to be considered during programming. The combination of RSP's hose packages with the swivel tool changer does in addition significantly reduce the design and installation times for the system integrator.

1.2 Documents

This *Technical Description* contains product information and data, drawings, circuit and pneumatic diagrams and lists of spare parts. In the document *Installation and Maintenance* (M0412-1) procedures for mounting, installation and replacement of equipment are described together with descriptions of inspection, cleaning and lubrication activities including recommended maintenance intervals.

1.3 Wear parts

Wear parts should be replaced before considerable damage occurs. The interval depends on the number of tool changes and its working environment. Generally, the more contaminated environment, the closer maintenance intervals.

The following parts are considered as wear parts:

- Signal pins
- Air sealings
- O-rings

1.4 Complementary Equipment

Complementary equipment is described in separate documents.

Article	Note
External valve units	Mounted at the rear of the upper arm. Shuts off the air automatically during tool changing.
Cable and Hose Package	Complete packages for most robots on the market ready to be mounted without any modifications.
Tool parking systems	RSP tool parking systems give rigid installations for easy tool changing.
Connection kits	Connection kits for tool changers and tool attachments simplifying electrical installations.
3D-models	Available in Solid Works®, STEP, X_T and IGES-format.

2 TECHNICAL SPECIFICATIONS

2.1 Description of swivel tool changers and tool attachments

This document presents the Robot System Products STC20-4 and STC20-4E swivel tool changers including tool attachments dedicated for material handling. Likewise presented are adaptation kits, connection kits to facilitate electrical installation and a tool stand kit.

The swivel tool changer STC20-4 transfers compressed air to the tool. They can be equipped with transfer of electrical signals, via spring loaded signal pins, to the tool attachment. The electrical version is designated 'E'. The swivel tool changers STC20-4 and STC20-4E cannot transport fluids.

The spring-loaded signal pins of STC20-4E are placed and protected along a circle close to the centre of the swivel tool changer. The signal pins are not in connection until at the very end of the docking cycle when the tool attachment is already properly aligned. This guarantees a minimum of wear of pins and contact surfaces.

The electrical unit can be used for identification and checking the presence of tools by using signal jumpers and binary coding of signals on the tool attachment.

For other bolt circles adaptation plates between the swivel tool changer and the turning disc on the robot may be needed. Such adaptation plates are available from RSP.



STC20

2.1.1 Coordinate System Definition

A swivel tool changer adds load to the robot. If the arm and tool loads are not stated correctly during programming the behaviour of the robot and the wear of the equipment will be affected. Information about weight and centre of gravity can, in accordance with the co-ordinate system stated below, be found in the technical specification tables of the swivel tool changers.

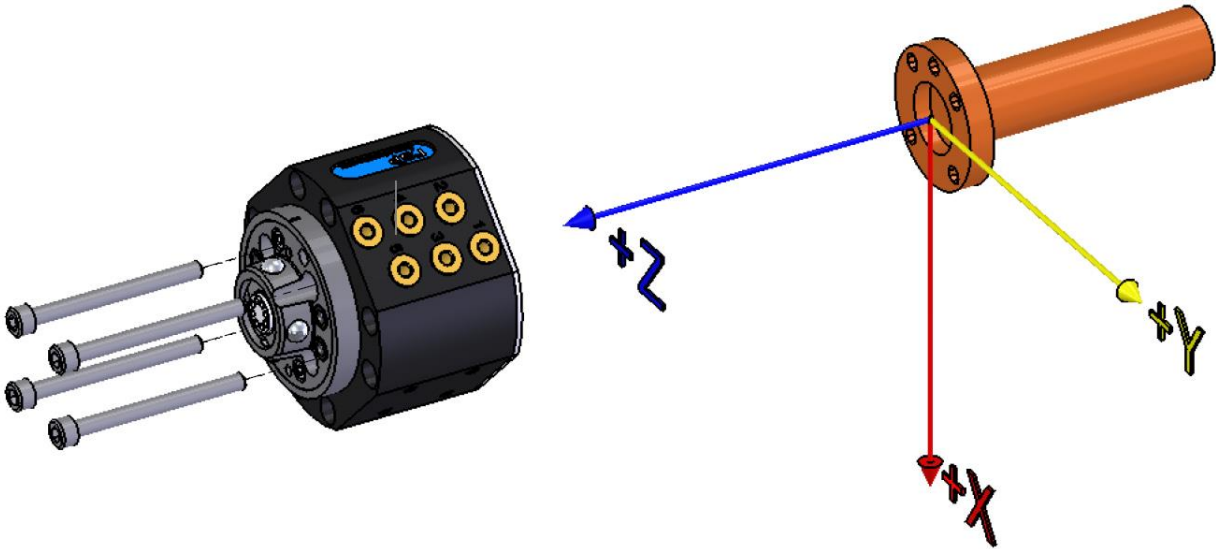

NOTE! For the tool changer and tool changer with tool attachment, the origin of the co-ordinate system is situated in the centre of the robot mounting flange.

2.1.2 Swivel with tool changer STC20-4. Article: P0106A

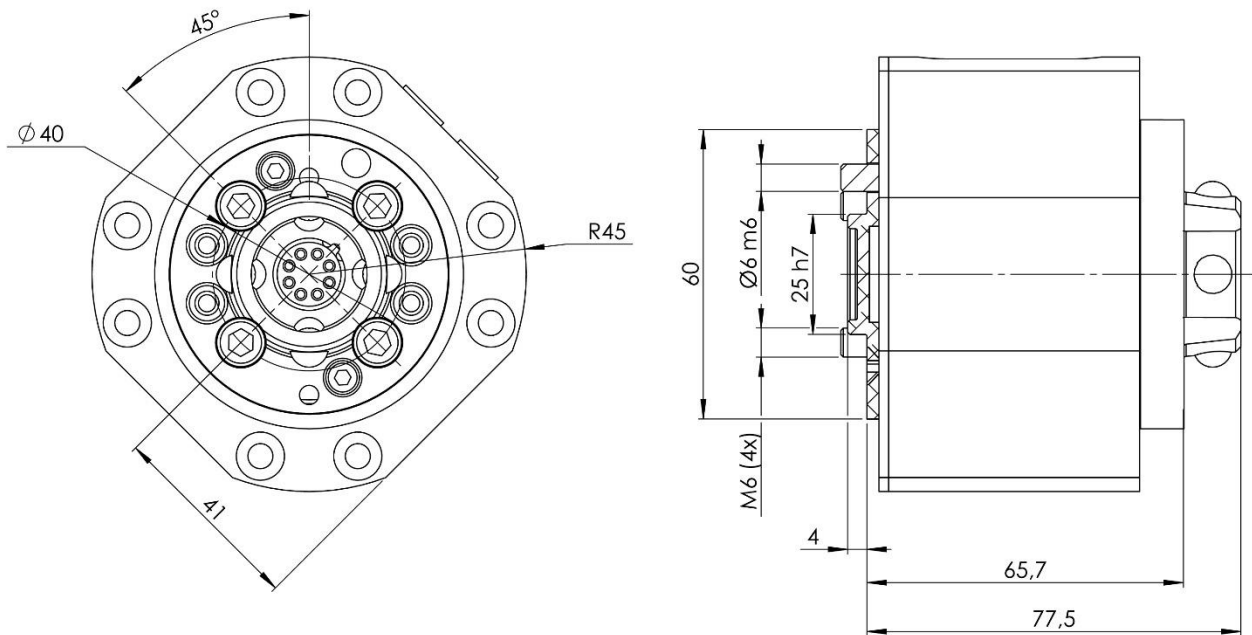

Swivel with tool changer STC20-4 transfers 4 pneumatic channels to the tool attachment and has separate inlets for Open TC and Close TC. To be used together with P0102 and P0123.

Technical data

Working temperature		+10°C–+50°C
Bolt pattern		ISO 9409-1-40-4-M6
Maximum tool load	Fz (static)	±200 N
	Mx/My (dynamic)	±200 Nm
	Mz (dynamic)	±100 Nm
Weight and centre of gravity (Z)		
P0106A		0.8 kg / 39 mm
P0106A with P0102		0.9 kg / 44 mm
P0106A with P0123		1.1 kg / 49 mm
Rotational torque		5 Nm
Air channels	Pneumatic diagram	See section 2.1.8 .
	User channels, robot side	4 x M5 (150 l/min, max 10 bar)
	Dedicated channels, M5	Open TC marked 6 (6-10 bar) Close TC marked 5 (6-10 bar)
	Air quality	Oil-clean and waterless filtered air, with max 25µm particle content

2.1.3 Tool attachment TA20-4, Article: P0102

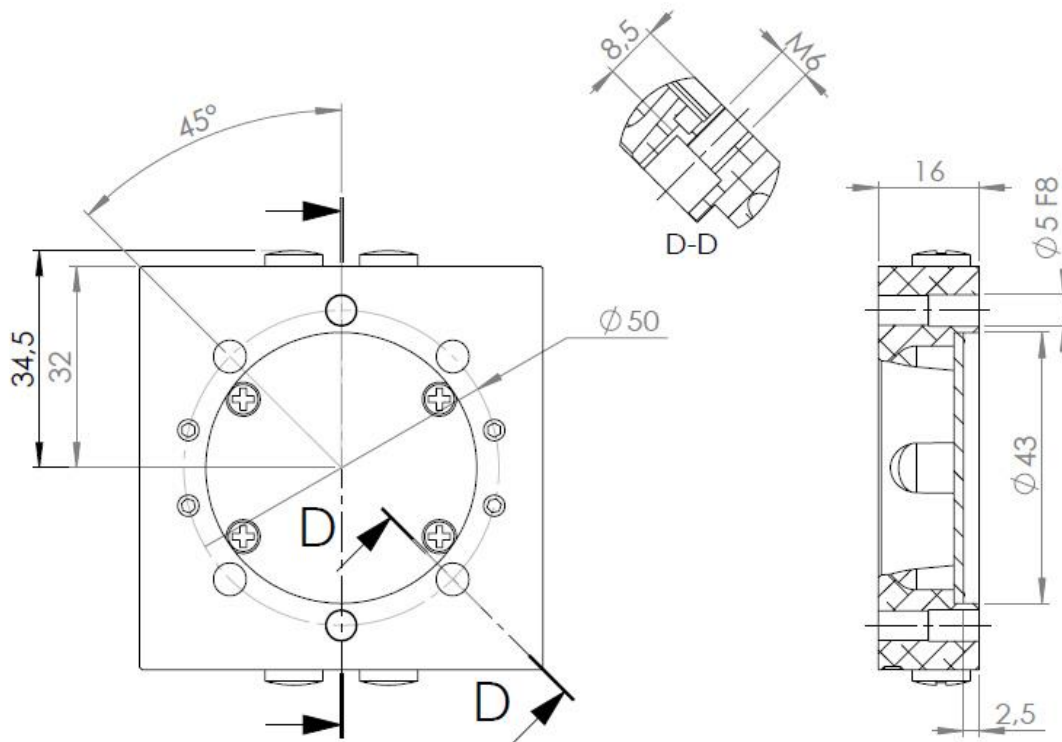

Tool attachment TA20-4 transfers 4 pneumatic channels to the tool. To be used together with P0106A.

Technical data

Working temperature		+10°C–+50°C
Bolt pattern		ISO 9409-1-50-4-M6
Weight		0.1 kg
Maximum tool load (M6-screws)	Fz (static)	±200 N
	Mx/My (dynamic)	±100 Nm
	Mz (dynamic)	±100 Nm
Maximum tool load (M5-screws)	Fz (static)	±200 N
	Mx/My (dynamic)	±100 Nm
	Mz (dynamic)	±75 Nm
Air channels	Connections, tool side	4 x M5



NOTE!

Tools can be mounted to the tool attachment using four M6-screws, alternatively the tool attachment can be mounted to the tool using four M5-screws.

2.1.4 Tool attachment TA20-4 steel, Article: P0123

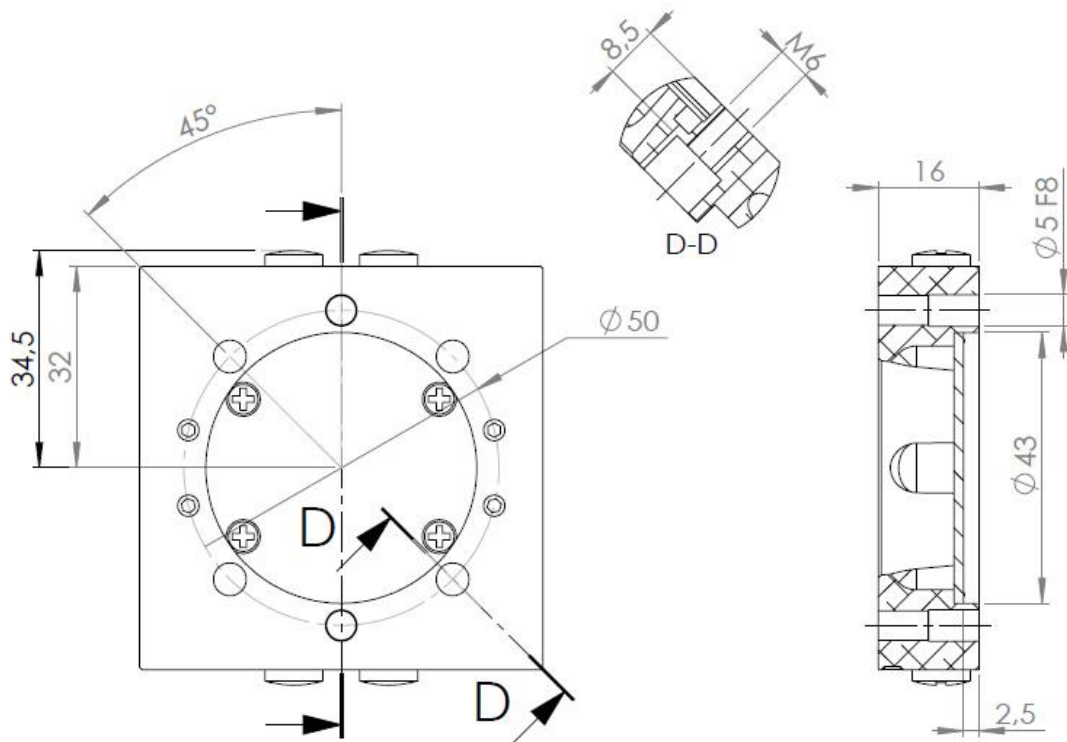

Tool attachment TA20-4 transfers 4 pneumatic channels to the tool. To be used together with P0106A.

Technical data

Working temperature		+10°C–+50°C
Bolt pattern		ISO 9409-1-50-4-M6
Weight		0.3 kg
Maximum tool load (M6-screws)	Fz (static)	±200 N
	Mx/My (dynamic)	±200 Nm
	Mz (dynamic)	±100 Nm
Maximum tool load (M5-screws)	Fz (static)	±200 N
	Mx/My (dynamic)	±200 Nm
	Mz (dynamic)	±75 Nm
Air channels	Connections, tool side	4 x M5



NOTE!

Tools can be mounted to the tool attachment using four M6-screws, alternatively the tool attachment can be mounted to the tool using four M5-screws.

2.1.5 Swivel with tool changer STC20-4E. Article: P0108A

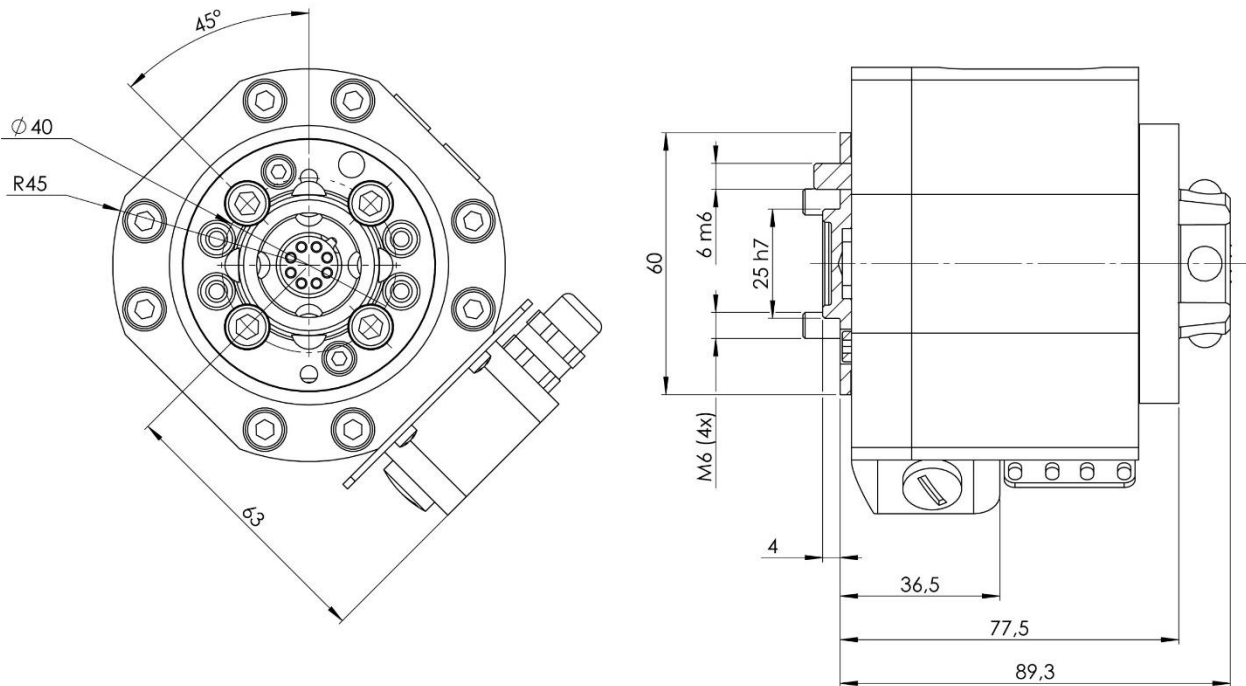

Swivel with tool changer STC20-4 transfers 4 pneumatic channels and 8 electrical signals to the tool attachment and has separate inlets for Open TC and Close TC. To be used together with P0109 and P0125.

Technical data

Working temperature		+10°C–+50°C
Bolt pattern		ISO 9409-1-40-4-M6
Maximum tool load	Fz (static)	± 200 N
	Mx/My (dynamic)	± 200 Nm
	Mz (dynamic)	± 100 Nm
Weight and centre of gravity (Z)		
P0108A		1.1 kg / 42 mm
P0108A with P0109		1.2 kg / 46 mm
P0108A with P0125		1.4 kg / 52mm
Rotational torque		6 Nm
Air channels	Pneumatic diagram	See section 2.1.8 .
	User channels, robot side Dedicated channels, M5	4 x M5 (150 l/min, max 10 bar) Open TC marked 6 (6-10 bar) Close TC marked 5 (6-10 bar)
	Air quality	Oil-clean and waterless filtered air, with max 25µm particle content
Electrical signals	Circuit diagram	E0208-001 (section 2.1.9)
	Total signals	8 x (0.5 A, 30V)
	Dedicated signals	24V, 0V, TC Coupled
	Connection, robot side	M12 8P, A-coded
Connection kits (optional)	P0025 (cable kit)	M12 8P–M12 8S, 2-meter cable (0,25 mm ²)
	P0025-30 (cable kit)	M12 8P–M12 8S, 3-meter cable (0,25 mm ²)

2.1.6 Tool attachment TA20-4E, Article: P0109

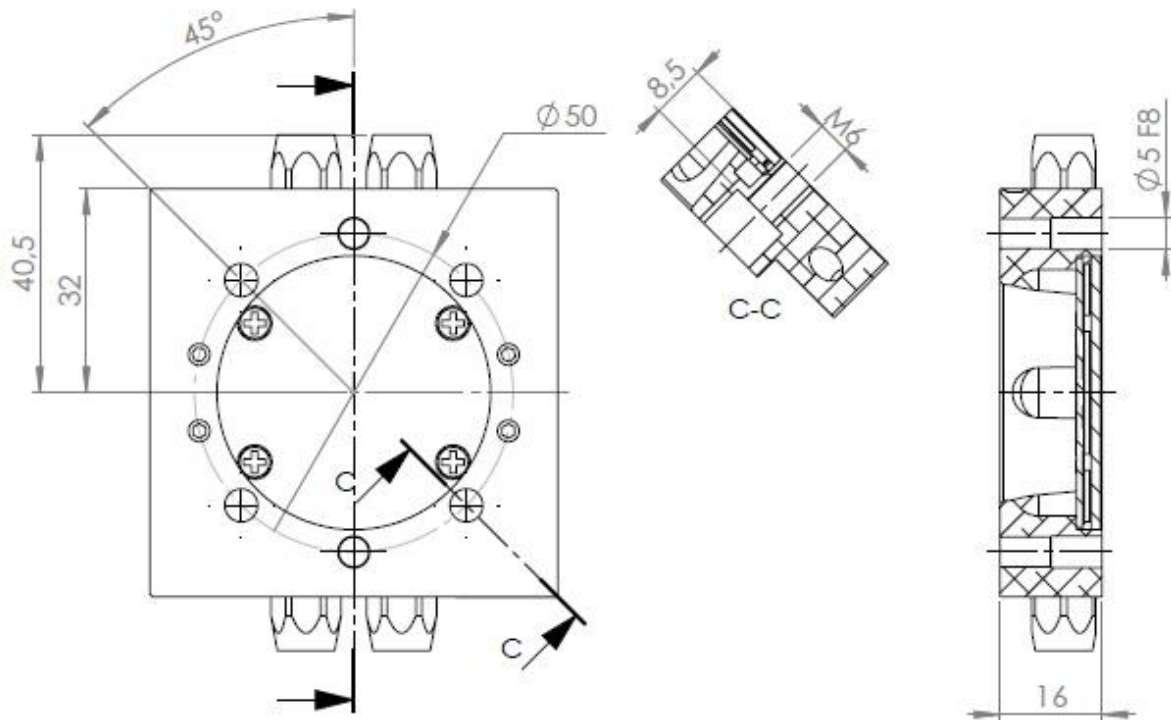

Tool attachment TA20-4E transfers 4 pneumatic channels and 4 electrical signals to the tool. To be used together with P0108A.

Technical data

Working temperature		+10°C–+50°C
Bolt pattern		ISO 9409-1-50-4-M6
Weight		0.1 kg
Maximum tool load (M6-screws)	Fz (static) Mx/My (dynamic) Mz (dynamic)	±200 N ±100 Nm ±100 Nm
Maximum tool load (M5-screws)	Fz (static) Mx/My (dynamic) Mz (dynamic)	±200 N ±100 Nm ±75 Nm
Air channels	Connections, tool side	4 x M5
Electrical signals	Connection, tool side	4 x M8 3S (signal, 24 V, 0V)
Connection kit (optional)	I0822 (cable kit)	M8 3P, 2-meter cable, open end



NOTE!

Tools can be mounted to the tool attachment using four M6-screws, alternatively the tool attachment can be mounted to the tool using four M5-screws.

2.1.7 Tool attachment TA20-4E steel, Article: P0125

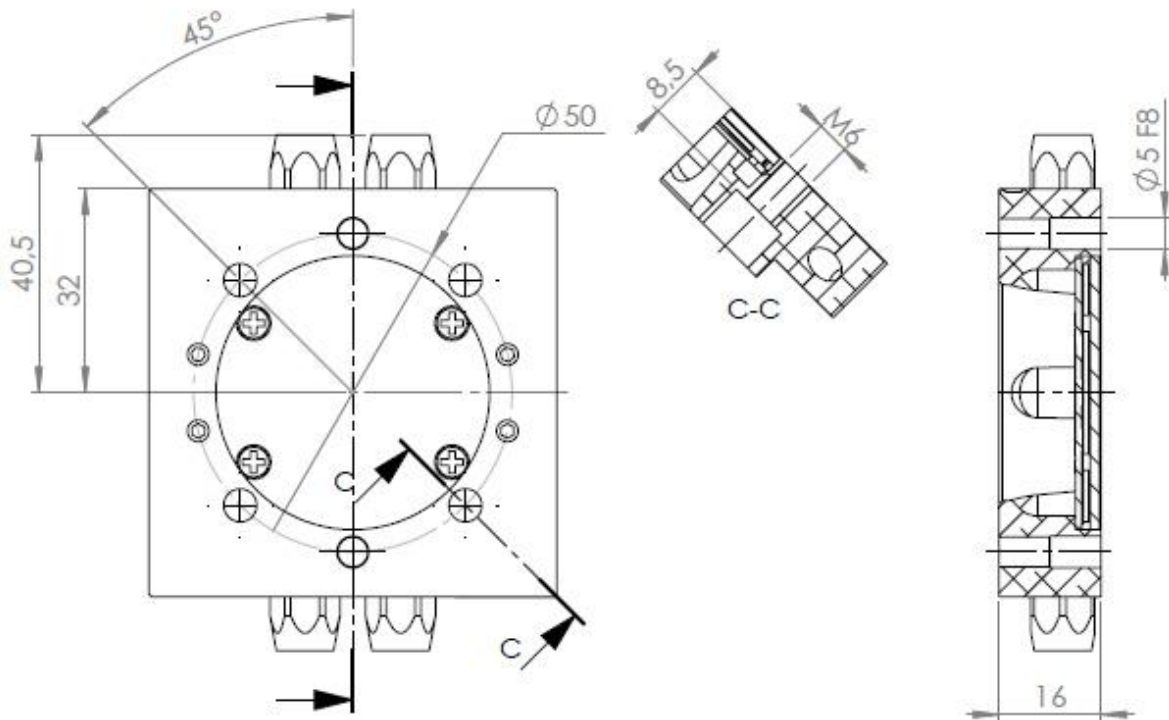

Tool attachment TA20-4E transfers 4 pneumatic channels and 4 electrical signals to the tool. To be used together with P0108A.

Technical data

Working temperature		+10°C–+50°C
Bolt pattern		ISO 9409-1-50-4-M6
Weight		0.3 kg
Maximum tool load (M6-screws)	Fz (static) Mx/My (dynamic) Mz (dynamic)	±200 N ±200 Nm ±100 Nm
Maximum tool load (M5-screws)	Fz (static) Mx/My (dynamic) Mz (dynamic)	±200 N ±200 Nm ±75 Nm
Air channels	Connections, tool side	4 x M5
Electrical signals	Connection, tool side	4 x M8 3S (signal, 24 V, 0V)
Connection kit (optional)	I0822 (cable kit)	M8 3P, 2-meter cable, open end



NOTE!

Tools can be mounted to the tool attachment using four M6-screws, alternatively the tool attachment can be mounted to the tool using four M5-screws.

2.1.8 Pneumatic diagram

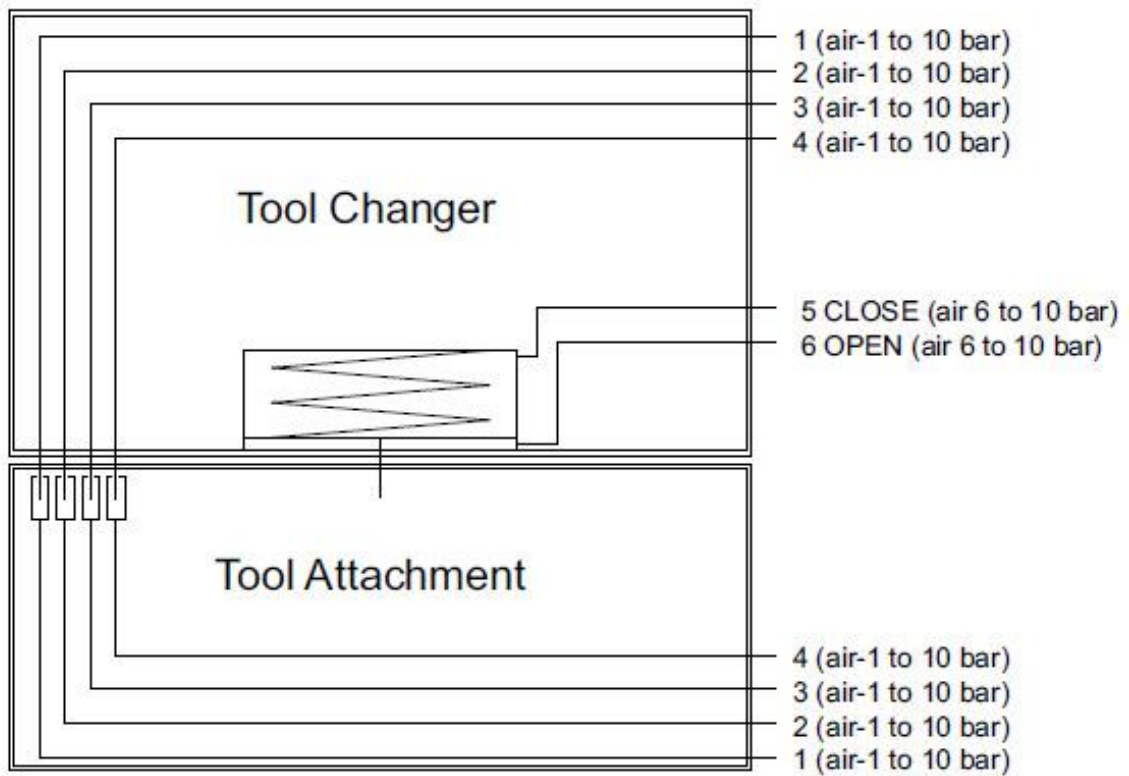

2.1.9 Circuit diagram E0208-001 for P0108A with P0109/P0125

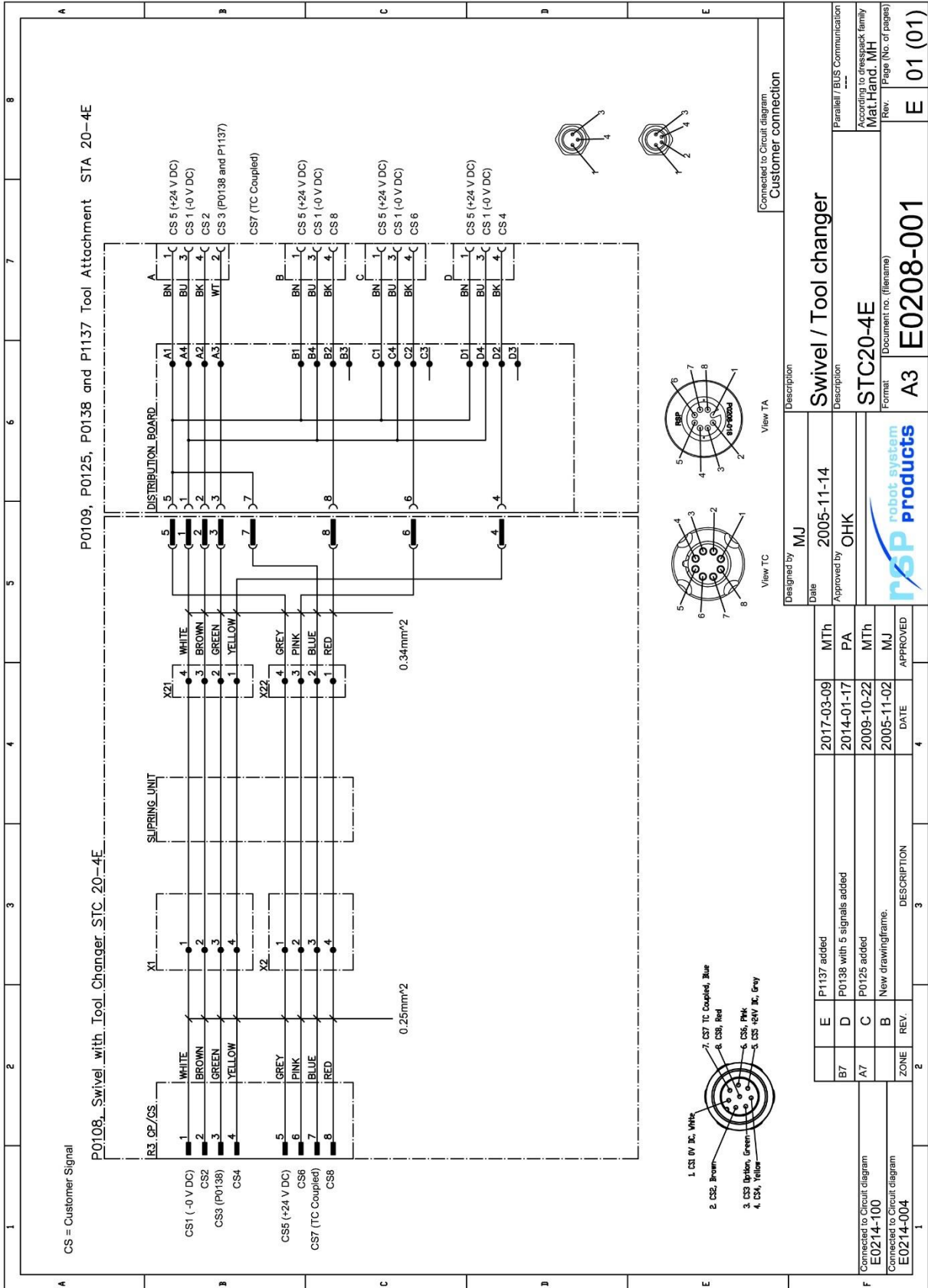

We reserve rights in this document and in the information contained therein. Reproduction use or disclosure to third parties without express authority is strictly prohibited. Robot System Products

2.2 Options for swivel tool changer

2.2.1 Robot adaptation kits

A robot adaptation kit is mandatory for mounting of a swivel tool changer to a robot. The adaptation kits always include rotation stops which are prohibiting the swivel tool changers to rotate in relation to the robots. Dependent on robot model an adaptation kit may also include an adaptation plate for other bolt circles. Robot adaptation kits are available from RSP.

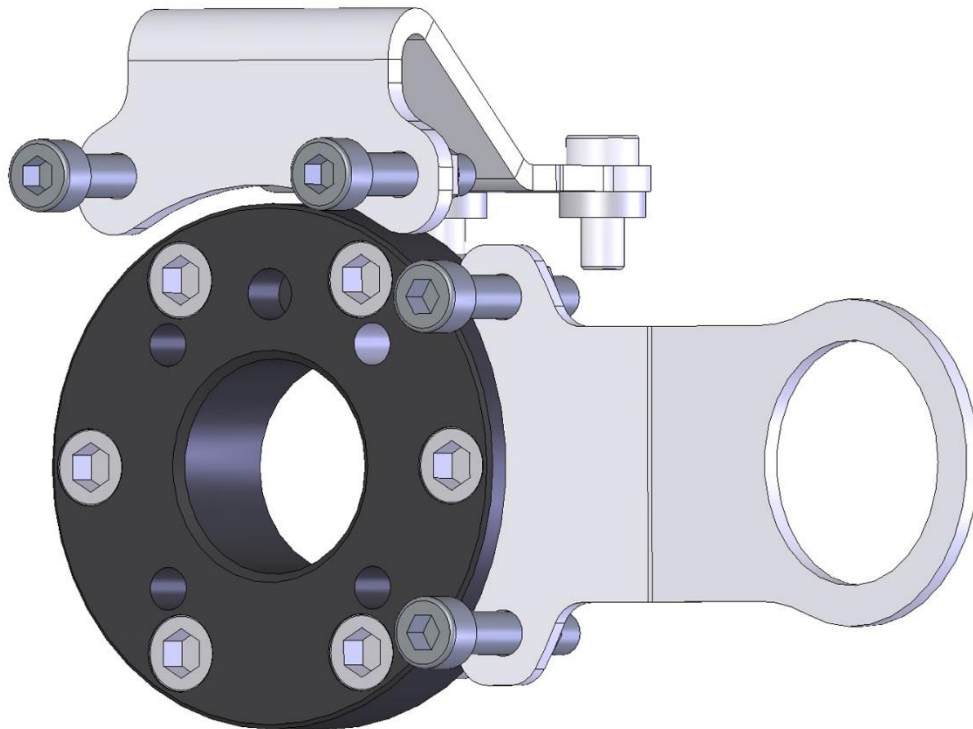

Example of adaptation kit including rotation stop, adaptation plate and hose holder



NOTE! Dependent on robot model and rotation stop, there can be limitations on the freedom of movement of axis 5. Contact Robot System Products for more information.

2.2.2 Tool Identification

Jumpers on signals at the tool attachment can be used to give information about which tool attachment that is docked in the swivel tool changer.

2.2.3 Limitation of Robot movements

There can be some limitations on the movement of axis 5 for some robot models. Contact Robot System Products for more information.

2.2.4 Tool stand kit 20. Article: P0142

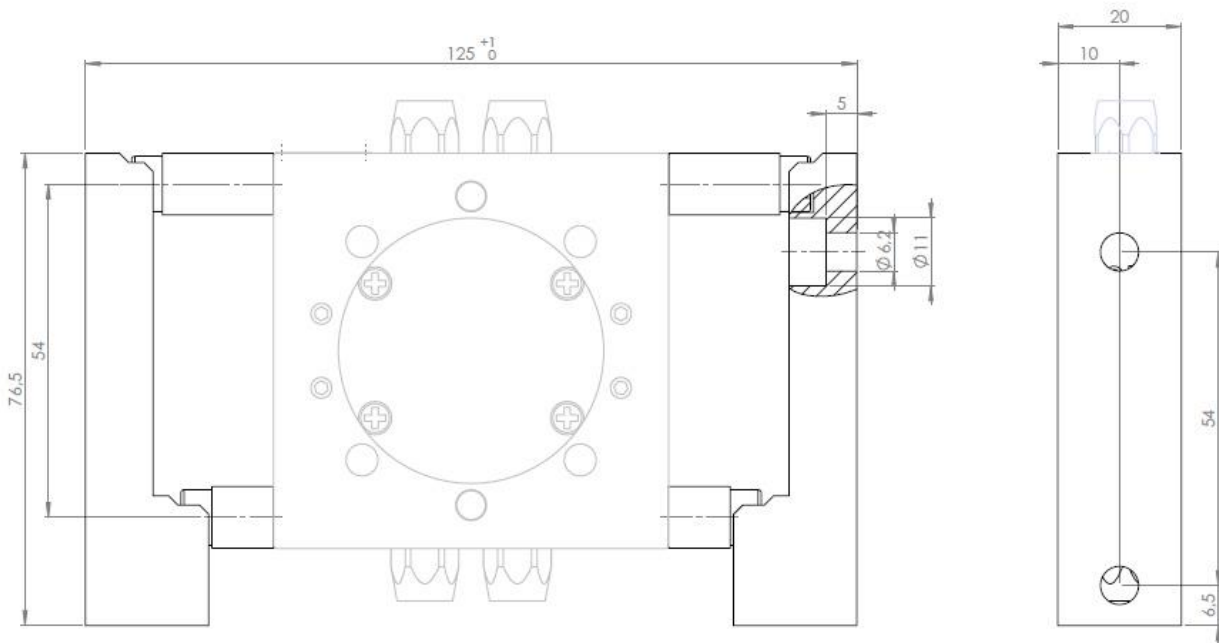

This tool stand kit gives, mounted on a stand, gives in combination with tool attachments P0109 or P0125 a robust tool stand for easy tool changing.

Technical data

Weight	0.3 kg
Maximum load	20 kg

3 SPARE PARTS

3.1 Part list for swivel tool changer P0106A and P0108A



Item	Description	Part number	Wear part	Pcs
1	Locking screw M6x80	21212519-386		4
2	Spring loaded signal pins (P0108A only)	I0223	X	8
3	Air sealing	I0158	X	4

